

INDEX

P/N	Page
1BJ (BSP MALE 60° SEAT/JIC MALE 74° CONE)	4
1BJ4 (45° BSP MALE 60° SEAT/ JIC MALE 74° CONE).....	6
1BJ9 (90° BSP MALE 60° SEAT/JIC MALE 74° CONE).....	7
1BN(BSP MALE 60° SEAT/NPT MALE).....	8
1BN9(90° BSP MALE 60° SEAT/NPT MALE).....	10
1BO(BSP MALE 60° SEAT/SAE O-RING BOSS).....	11
1BO4-OG (45° BSP MALE 60° SEAT/SAE O-RING BOSS).....	13
1BO9-OG(90° BSP MALE 60° SEAT/SAE O-RING BOSS).....	14
1BP (BSP MALE 60° SEAT/SAE MALE 90° CONE).....	15
1FG (ORFS MALE FLAT/BSP O-RING SEAL).....	16
1FG9-OG(90° ORFS MALE/BSP MALE WITH O-Ring).....	17
1FT-SP(ORFS MALE/BSPT MALE).....	18
1JB-WD(JIC MALE 74° CONE/BSP MALE CAPTIVE SEAL).....	19
1JG(JIC MALE 74° CONE/BSP MALE WITH O-RING).....	21
1JG4-OG(45° JIC MALE 74° CONE/BSP MALE WITH O-RING).....	23
1JG9-OG(90° JIC MALE 74° CONE/BSP MALE WITH O-RING).....	24
1JT-SP(JIC MALE 74° CONE/BSPT MALE).....	26
1JT4-SP(45° JIC MALE 74° CONE/BSPT MALE).....	28
1JT9-SP(90° JIC MALE 74°/BSPT MALE).....	30
1NT-SP(NPT MALE/BSPT MALE).....	32

1OT-SP(SAE O-RING BOSS/BSPT MALE).....	33
1OT9-OG(90° BSPT MALE/SAE O-RING BOSS).....	34
1TP-SP(BSPT MALE/SAE MALE 90° CONE).....	35
1TP4-SP(45° BSPT MALE/SAE MALE 90° CONE).....	36
1TP9-SP(90° BSPT MALE/SAE MALE 90° CONE).....	36
2BF(BSP MALE 60° SEAT/ORFS FEMALE).....	37
2BJ(BSP MALE 60° SEAT/JIC FEMALE 74° SEAT).....	38
2BJ4(45° BSP MALE 60° SEAT/JIC FEMALE 74° CONE).....	39
2BJ9(90° BSP MALE 60° SEAT/JIC FEMALE 74° SEAT).....	40
2GJ(BSP MALE O-RING/JIC FEMALE 74° CONE).....	41
2GJ9-OG(90° BSPP MALE O-RING/JIC FEMALE 74° CONE).....	42
2JA(JIC MALE / BSP FEMALE MULTISEAL).....	43
2JB(JIC MALE 74° CONE/BSP FEMALE 60° CONE).....	44
2JB4(45° JIC MALE 74° CONE/BSP FEMALE 60° CONE).....	45
2JB9(90° JIC MALE 74° CONE/BSP FEMALE 60° CONE).....	46
2NB(NPT MALE/BSP FEMALE 60° CONE).....	47
2NB4(45° NPT MALE/BSP FEMALE 60° CONE).....	48
2NB9(90° NPT MALE/BSP FEMALE 60° CONE).....	49
2OB(SAE O-RING BOSS/BSP FEMALE 60° CONE).....	50
2OB4-OG(SAE MALE WITH O-RING/BSP FEMALE 60° CONE).....	51
2OB9-OG(SAE O-RING BOSS/BSP FEMALE 60° CONE).....	52
2TJ-SP(BSPT MALE/JIC FEMALE 74° SEAT).....	53

2TJ4-SP(45° BSPT MALE/JIC FEMALE 74° SEAT).....	54
2TJ9-SP (90° BSPT MALE/JIC FEMALE 74° SEAT).....	55
3BJ(BSP FEMALE 60° CONE/JIC FEMALE 74° SEAT).....	56
5BN(BSP MALE 60° SEAT/NPT FEMALE).....	57
5GN(BSP MALE O-RING/NPT FEMALE).....	58
5JB(JIC MALE 74° CONE/BSP FEMALE).....	59
5JT(JIC MALE 74° CONE/BSPT FEMALE).....	60
5JT9(90° JIC MALE 74° CONE/BSPT FEMALE).....	61
5NB(NPT MALE/BSP FEMALE).....	62
5NT (NPT MALE/BSPT FEMALE).....	63
5OT(SAE O-RING BOSS/BSPT FEMALE).....	64
5TN-SP(BSPT MALE/NPT FEMALE).....	65
7BJ-S(BSP FEMALE/JIC FEMALE 74° SEAT).....	66
7NB-S(NPT FEMALE/BSP FEMALE 60° CONE).....	67
7NB4-S(45° NPT FEMALE/BSP FEMALE 60° CONE).....	68
7NB9-S(90° NPT FEMALE/BSP FEMALE 60° CONE).....	69
AFFG-OG(ORFS MALE/ORFS MALE/BSP MALE O-RING).....	70
AFGF(ORFS MALE/BSP MALE O-RING/ORFS MALE).....	71

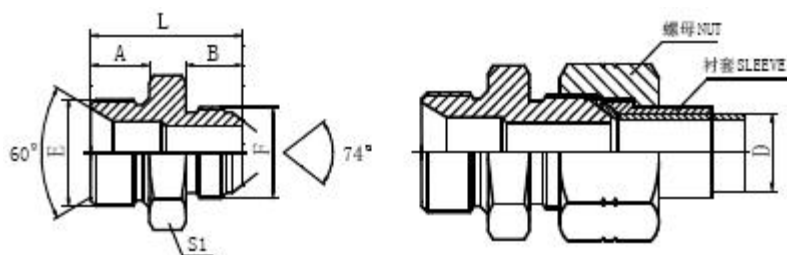

1BJ

英管外螺纹 60°内锥/美制 JIC 外螺纹 74°外锥

BSP MALE 60° SEAT/JIC MALE 74° CONE

代号 P/N	螺纹 Thread		O形圈 O-RING		尺寸 DIMENSIONS			
	E	F			A	B	L	S1
1BJ-02-04	G1/8"X28	7/16"X20			10	14	30	14
1BJ-02-05	G1/8"X28	1/2"X20			10	14	30	14
1BJ-02-06	G1/8"X28	9/16"X18			10	14.1	30	17
1BJ-04	G1/4"X19	7/16"X20			12	14	32	19
1BJ-04-05	G1/4"X19	1/2"X20			12	14	32	19
1BJ-04-06	G1/4"X19	9/16"X18			12	14.1	32	19
1BJ-04-08	G1/4"X19	3/4"X16			12	16.7	36.5	22
1BJ-04-10	G1/4"X19	7/8"X14			12	19.3	39	24
1BJ-06	G3/8"X19	9/16"X18			13.5	14.1	35.5	22
1BJ-06-04	G3/8"X19	7/16"X20			13.5	14	35.5	22
1BJ-06-05	G3/8"X19	1/2"X20			13.5	14	35.5	22
1BJ-06-08	G3/8"X19	3/4"X16			13.5	16.7	38.5	22
1BJ-06-10	G3/8"X19	7/8"X14			13.5	19.3	41	24
1BJ-06-12	G3/8"X19	1.1/16"X12			13.5	21.9	45	30
1BJ-08	G1/2"X14	3/4"X16			16	16.7	43	27
1BJ-08-04	G1/2"X14	7/16"X20			16	14	40	27
1BJ-08-05	G1/2"X14	1/2"X20			16	14	40	27
1BJ-08-06	G1/2"X14	9/16"X18			16	14.1	40	27
1BJ-08-10	G1/2"X14	7/8"X14			16	19.3	45.5	27
1BJ-08-12	G1/2"X14	1.1/16"X12			16	21.9	48	30

1BJ-08-14	G1/2"X14	1.3/16"X12			16	22.6	49.5	32
1BJ-10	G5/8"X14	7/8"X14			17.5	19.3	47	30
1BJ-10-08	G5/8"X14	3/4"X16			17.5	16.7	44	30
1BJ-10-12	G5/8"X14	1.1/16"X12			17.5	21.9	49.5	30
1BJ-10-16	G5/8"X14	1.5/16"X12			17.5	23.1	51.5	36
1BJ-12	G3/4"X14	1.1/16"X12			18.5	21.9	51.5	32
1BJ-12-08	G3/4"X14	3/4"X16			18.5	16.7	46.5	32
1BJ-12-10	G3/4"X14	7/8"X14			18.5	19.3	49	32
1BJ-12-14	G3/4"X14	1.3/16"X12			18.5	22.6	52	32
1BJ-12-16	G3/4"X14	1.5/16"X12			18.5	23.1	52.5	34
1BJ-12-20	G3/4"X14	1.5/8"X12			18.5	24.3	55.8	46
1BJ-16	G1"X11	1.5/16"X12			20.5	23.1	57	41
1BJ-16-10	G1"X11	7/8"X14			20.5	19.3	53	41
1BJ-16-12	G1"X11	1.1/16"X12			20.5	21.9	55.5	41
1BJ-16-14	G1"X11	1.3/16"X12			20.5	22.6	56	41
1BJ-16-20	G1"X11	1.5/8"X12			20.5	24.3	58	46
1BJ-20	G1.1/4"X11	1.5/8"X12			20.5	24.3	62	50
1BJ-20-12	G1.1/4"X11	1.1/16"X12			20.5	21.9	55.5	46
1BJ-20-16	G1.1/4"X11	1.5/16"X12			20.5	23.1	60.5	50
1BJ-20-24	G1.1/4"X11	1.7/8"X12			20.5	27.5	63	50
1BJ-24-16	G1.1/2"X11	1.5/16"X12			23	23.1	61	55
1BJ-24-20	G1.1/2"X11	1.5/8"X12			23	24.3	62.5	55
1BJ-24	G1.1/2"X11	1.7/8"X12			23	27.5	67.5	55
1BJ-24-32	G1.1/2"X11	2.1/2"X12			23	33.9	74	65
1BJ-32	G2"X11	2.1/2"X12			25.5	33.9	77.5	70
1BJ-32-24	G2"X11	1.7/8"X12			25.5	27.5	70	70

Note: Nut and sleeve should be ordered separately. The nut NB200 and sleeve NB500 is suitable for metric tube, the nut NB200 and sleeve NB300 is suitable for inch tube.

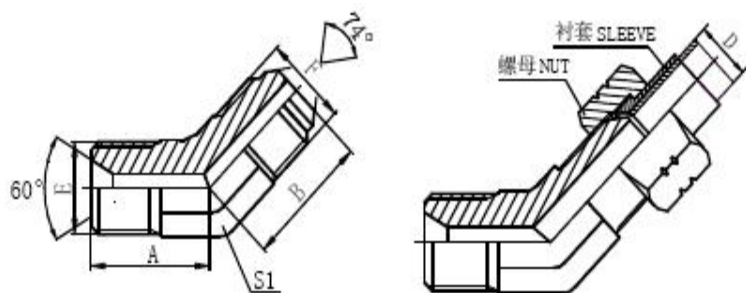

1BJ4

45°英管外螺纹 60°内锥/美制 JIC 外螺纹 74°外锥

45° BSP MALE 60° SEAT/ JIC MALE 74° CONE

代号 P/N	螺纹 Thread		O形圈 O-RING		尺寸 DIMENSIONS			
	E	F			A	B	S1	
1BJ4-04	G1/4"X19	7/16"X20			20.3	22.3	14	
1BJ4-04-05	G1/4"X19	1/2"X20			20.5	22.5	14	
1BJ4-06	G3/8"X19	9/16"X18			21	23	16	
1BJ4-06-08	G3/8"X19	3/4"X16			23	26.8	19	
1BJ4-08	G1/2"X14	3/4"X16			27	28	22	
1BJ4-08-10	G1/2"X14	7/8"X14			27	32	22	
1BJ4-10	G5/8"X14	7/8"X14			28.5	31	22	
1BJ4-12	G3/4"X14	1.1/16"X12			31	35.5	27	
1BJ4-16	G1"X11	1.5/16"X12			35	38.5	33	

Note: Nut and sleeve should be ordered separately. The nut NB200 and sleeve NB500 is suitable for metric tube, the nut NB200 and sleeve NB300 is suitable for inch tube.

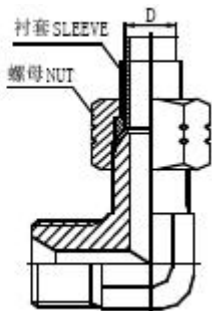
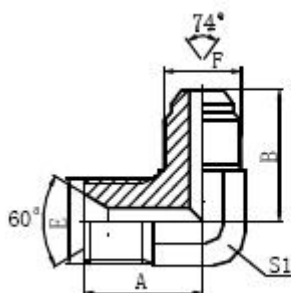

1BJ9

90°英管外螺纹 60°内锥/美制 JIC 外螺纹 74°外锥

90° BSP MALE 60° SEAT/JIC MALE 74° CONE

代号 P/N	螺纹 Thread		O形圈 O-RING		尺寸 DIMENSIONS			
	E	F			A	B	S1	
1BJ9-04	G1/4"X19	7/16"X20			24.5	26.6	14	
1BJ9-04-05	G1/4"X19	1/2"X20			24.5	26.6	14	
1BJ9-04-06	G1/4"X19	9/16"X18			24.5	26.9	14	
1BJ9-06	G3/8"X19	9/16"X18			27.5	28.5	16	
1BJ9-06-08	G3/8"X19	3/4"X16			28.5	32	19	
1BJ9-08	G1/2"X14	3/4"X16			34.5	34.8	22	
1BJ9-08-10	G1/2"X14	7/8"X14			34.5	37.8	22	
1BJ9-10	G5/8"X14	7/8"X14			35	37.8	22	
1BJ9-12	G3/4"X14	1.1/16"X12			40	44.2	27	
1BJ9-16	G1"X11	1.5/16"X12			46	49	33	
1BJ9-16-20	G1"X11	1.5/8"X12			50.5	55.5	41	

Note: Nut and sleeve should be ordered separately. The nut NB200 and sleeve NB500 is suitable for metric tube, the nut NB200 and sleeve NB300 is suitable for inch tube.

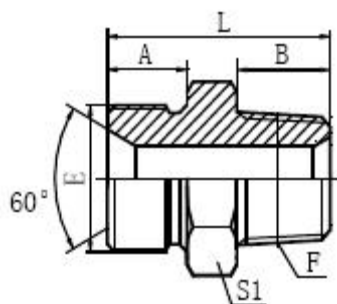

1BN

英管外螺纹 60°内锥/美制布锥管外螺纹

BSP MALE 60° SEAT/NPT MALE

代号 P/N	螺纹 Thread		O形圈 O-RING		尺寸 DIMENSIONS			
	E	F			A	B	L	S1
1BN-02	G1/8"X28	Z1/8"X27			10	10.5	26	14
1BN-02-04	G1/8"X28	Z1/4"X18			10	15	31	17
1BN-04	G1/4"X19	Z1/4"X18			12	15	33	19
1BN-04-02	G1/4"X19	Z1/8"X27			12	10.5	28	19
1BN-04-06	G1/4"X19	Z3/8"X18			12	16	34	19
1BN-04-08	G1/4"X19	Z1/2"X14			12	19.5	39.5	22
1BN-06	G3/8"X19	Z3/8"X18			13.5	16	37.5	22
1BN-06-04	G3/8"X19	Z1/4"X18			13.5	15	36	22
1BN-06-08	G3/8"X19	Z1/2"X14			13.5	19.5	41	22
1BN-06-12	G3/8"X19	Z3/4"X14			13.5	19.5	43	30
1BN-08	G1/2"X14	Z1/2"X14			16	19.5	45.5	27
1BN-08-06	G1/2"X14	Z3/8"X18			16	16	42	27
1BN-08-12	G1/2"X14	Z3/4"X14			16	19.5	45.5	30
1BN-08-16	G1/2"X14	Z1"X11.5			16	25.5	52.5	36
1BN-10-08	G5/8"X14	Z1/2"X14			17.5	19.5	47	30
1BN-10-12	G5/8"X14	Z3/4"X14			17.5	19.5	47	30
1BN-12	G3/4"X14	Z3/4"X14			18.5	19.5	49	32
1BN-12-04	G3/4"X14	Z1/4"X18			18.5	15	43.5	32
1BN-12-06	G3/4"X14	Z3/8"X18			18.5	16	45.5	32
1BN-12-08	G3/4"X14	Z1/2"X14			18.5	19.5	49	32

1BN-12-16	G3/4"X14	Z1"X11.5			18.5	25.5	55	36
1BN-16	G1"X11	Z1"X11.5			20.5	25.5	59	41
1BN-16-08	G1"X11	Z1/2"X14			20.5	20	52.5	41
1BN-16-12	G1"X11	Z3/4"X14			20.5	19.5	53	41
1BN-16-20	G1"X11	Z1.1/4"X1			20.5	26.5	60	46
1BN-20	G1.1/4"X1	Z1.1/4"X1			20.5	26.5	62	50
1BN-20-16	G1.1/4"X1	Z1"X11.5			20.5	25.5	61	50
1BN-20-24	G1.1/4"X1	Z1.1/2"X1			20.5	27.5	63	50
1BN-24	G1.1/2"X1	Z1.1/2"X1			23	27.5	65.5	55
1BN-24-20	G1.1/2"X1	Z1.1/4"X1			23	26.5	64.5	55
1BN-24-32	G1.1/2"X1	Z2"X11.5			23	27.5	67.5	65
1BN-32	G2"X11	Z2"X11.5			25.5	27.5	70	70
1BN-32-20	G2"X11	Z1.1/4"X1			25.5	26.5	69	70
1BN-32-24	G2"X11	Z1.1/2"X1			25.5	27.5	70	70

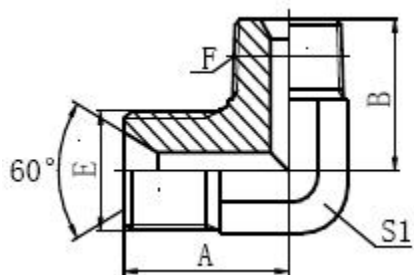

1BN9

90°英管外螺纹 60°内锥/美制布锥管外螺纹

90°BSP MALE 60°SEAT/NPT MALE

代号 P/N	螺纹 Thread		O形圈 O-RING		尺寸 DIMENSIONS			
	E	F			A	B	S1	
1BN9-04	G1/4"X19	Z1/4"X18			24.5	25.5	14	
1BN9-04-02	G1/4"X19	Z1/8"X27			24.5	23.5	14	
1BN9-06	G3/8"X19	Z3/8"X18			28.5	31	19	
1BN9-06-04	G3/8"X19	Z1/4"X18			27.5	26.5	16	
1BN9-06-08	G3/8"X19	Z1/2"X14			31	36.7	22	
1BN9-06-12	G3/8"X19	Z3/4"X14			34.5	44	27	
1BN9-08	G1/2"X14	Z1/2"X14			34.5	37.5	22	
1BN9-08-06	G1/2"X14	Z3/8"X18			34.5	33	22	
1BN9-12	G3/4"X14	Z3/4"X14			38	43.5	27	
1BN9-12-08	G3/4"X14	Z1/2"X14			40	40	27	
1BN9-12-16	G3/4"X14	Z1"X11.5			41	50	33	
1BN9-16	G1"X11	Z1"X11.5			46	50	33	
1BN9-16-12	G1"X11	Z3/4"X14			46	45.2	33	

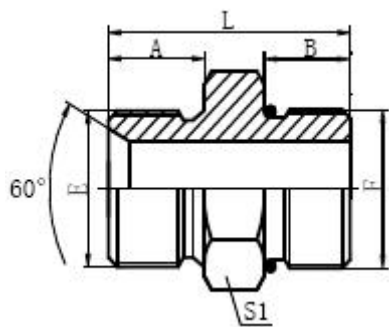

1BO

英管外螺纹 60°内锥/美制 SAE O 形圈

BSP MALE 60° SEAT/SAE O-RING BOSS

代号 P/N	螺纹 Thread		O 形圈 O-RING		尺寸 DIMENSIONS			
	E	F		F END	A	B	L	S1
1BO-04	G1/4"X19	7/16"X20		8.92X1.83	12	9.14	27	19
1BO-04-05	G1/4"X19	1/2"X20		10.52X1.83	12	9.14	27	19
1BO-04-06	G1/4"X19	9/16"X18		11.89X1.98	12	9.93	28	19
1BO-04-08	G1/4"X19	3/4"X16		16.36X2.21	12	11.13	31	22
1BO-04-10	G1/4"X19	7/8"X14		19.18X2.46	12	12.7	34.5	27
1BO-06	G3/8"X19	9/16"X18		11.89X1.98	13.5	9.93	31.5	22
1BO-06-04	G3/8"X19	7/16"X20		8.92X1.83	13.5	9.14	30.5	22
1BO-06-08	G3/8"X19	3/4"X16		16.36X2.21	13.5	11.13	32.5	22
1BO-06-10	G3/8"X19	7/8"X14		19.18X2.46	13.5	12.7	36.5	27
1BO-08	G1/2"X14	3/4"X16		16.36X2.21	16	11.13	37	27
1BO-08-05	G1/2"X14	1/2"X20		10.52X1.83	16	9.14	35	27
1BO-08-06	G1/2"X14	9/16"X18		11.89X1.98	16	9.93	36	27
1BO-08-10	G1/2"X14	7/8"X14		19.18X2.46	16	12.7	38.5	27
1BO-08-12	G1/2"X14	1.1/16"X12		23.47X2.95	16	15.09	42	32
1BO-08-16	G1/2"X14	1.5/16"X12		29.74X2.95	16	15.09	42	38
1BO-10	G5/8"X14	7/8"X14		19.18X2.46	17.5	12.7	40	30
1BO-10-08	G5/8"X14	3/4"X16		16.36X2.21	17.5	11.13	38.5	30
1BO-10-12	G5/8"X14	1.1/16"X12		23.47X2.95	17.5	15.09	43.5	32
1BO-12	G3/4"X14	1.1/16"X12		23.47X2.95	18.5	15.09	44.5	32

1BO-12-08	G3/4"X14	3/4"X16		16.36X2.21	18.5	11.13	40.5	32
1BO-12-10	G3/4"X14	7/8"X14		19.18X2.46	18.5	12.7	42.5	32
1BO-12-14	G3/4"X14	1.3/16"X12		26.62X2.95	18.5	15.09	44.5	36
1BO-12-16	G3/4"X14	1.5/16"X12		29.74X2.95	18.5	15.09	44.5	38
1BO-12-20	G3/4"X14	1.5/8"X12		37.46X3.00	18.5	15.09	48.5	50
1BO-16	G1"X11	1.5/16"X12		29.74X2.95	20.5	15.09	48.5	41
1BO-16-10	G1"X11	7/8"X14		19.18X2.46	20.5	12.7	46.5	41
1BO-16-12	G1"X11	1.1/16"X12		23.47X2.95	20.5	15.09	48.5	41
1BO-16-14	G1"X11	1.3/16"X12		26.62X2.95	20.5	15.09	48.5	41
1BO-16-20	G1"X11	1.5/8"X12		37.46X3.00	20.5	15.09	50.5	50
1BO-20	G1.1/4"X1	1.5/8"X12		37.46X3.00	20.5	15.09	50.5	50
1BO-20-16	G1.1/4"X1	1.5/16"X12		29.74X2.95	20.5	15.09	50.5	50
1BO-24	G1.1/2"X1	1.7/8"X12		43.69X3.00	23	15.09	53	55

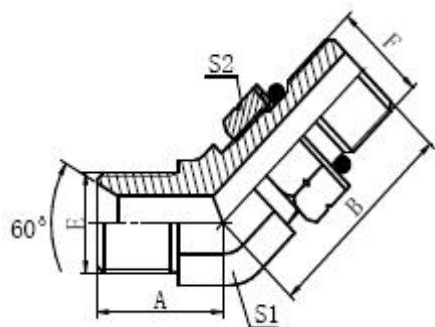

1BO4-OG

45°英管外螺纹 60°内锥/美制 SAE 外螺纹 O 形圈

45° BSP MALE 60° SEAT/SAE O-RING BOSS

代号 P/N	螺纹 Thread		O 形圈 O-RING		尺寸 DIMENSIONS			
	E	F		F END	A	B	S1	S2
1BO4-02-04OG	G/18"X28	7/16"X20		8.92X1.83	17	24	11	17
1BO4-02-05OG	G/18"X28	1/2"X20		10.52X1.83	17	26	14	17
1BO4-04OG	G1/4"X19	7/16"X20		8.92X1.83	22	26	14	17
1BO4-04-05OG	G1/4"X19	1/2"X20		10.52X1.83	22	26	14	17
1BO4-04-06OG	G1/4"X19	9/16"X18		11.89X1.98	22	27.5	14	19
1BO4-04-08OG	G1/4"X19	3/4"X16		16.36X2.21	22	31.5	19	24
1BO4-06-04OG	G3/8"X19	7/16"X20		8.92X1.83	21	28	16	17
1BO4-06OG	G3/8"X19	9/16"X18		11.89X1.98	22	28	16	19
1BO4-06-08OG	G3/8"X19	3/4"X16		16.36X2.21	23	31.5	19	24
1BO4-06-10OG	G3/8"X19	7/8"X14		19.18X2.46	24	38.5	22	27
1BO4-08OG	G1/2"X14	3/4"X16		16.36X2.21	27	33	22	24
1BO4-08-10OG	G1/2"X14	7/8"X14		19.18X2.46	27	38.5	22	27
1BO4-08-12OG	G1/2"X14	1.1/16"X12		23.47X2.95	28.5	43.5	27	32
1BO4-12-08OG	G3/4"X14	3/4"X16		16.36X2.21	32	38.6	27	24
1BO4-12OG	G3/4"X14	1.1/16"X12		23.47X2.95	32	43.9	27	32
1BO4-12-10OG	G3/4"X14	7/8"X14		19.18X2.46	32	42	27	27
1BO4-12-16OG	G3/4"X14	1.5/16"X12		29.74X2.95	32.5	45.5	33	41
1BO4-16OG	G1"X11	1.5/16"X12		29.74X2.95	34	45.5	33	41
1BO4-16-12OG	G1"X11	1.1/16"X12		23.47X2.95	34	45	33	32

1BO4-16-20OG	G1"X11	1.5/8"X12		37.46X3.00	38.5	48.5	41	50
1BO4-20OG	G1.1/4"X11	1.5/8"X12		37.46X3.00	38.5	48.5	41	50
1BO4-20-16OG	G1.1/4"X11	1.5/16"X12		29.74X2.95	38.5	48.5	41	41
1BO4-20-24OG	G1.1/4"X11	1.7/8"X12		43.69X3.00	41.5	50	48	55
1BO4-24OG	G1.1/2"X11	1.7/8"X12		43.69X3.00	44	50	48	55

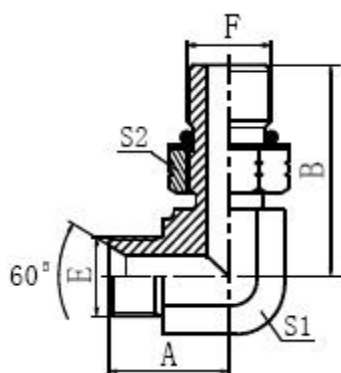

1BO9-OG

90°英管外螺纹 60°内锥/美制 SAE 外螺纹 O 形圈

90° BSP MALE 60° SEAT/SAE O-RING BOSS

代号 P/N	螺纹 Thread		O 形圈 O-RING		尺寸 DIMENSIONS			
	E	F		F END	A	B	S1	S2
1BO9-02-04OG	G1/8"X28	7/16"X20		8.92X1.83	19.8	27.2	11	17
1BO9-02-05OG	G1/8"X28	1/2"X20		10.52X1.83	22.3	30	14	17
1BO9-04OG	G1/4"X19	7/16"X20		8.92X1.83	25	30.5	14	17
1BO9-04-05OG	G1/4"X19	1/2"X20		10.52X1.83	25	29.9	14	17
1BO9-04-06OG	G1/4"X19	9/16"X18		11.89X1.98	24.5	31.8	14	19
1BO9-04-08OG	G1/4"X19	3/4"X16		16.36X2.21	27.5	37.5	19	24
1BO9-06-04OG	G3/8"X19	7/16"X20		8.92X1.83	27.5	31.5	16	17
1BO9-06OG	G3/8"X19	9/16"X18		11.89X1.98	27.5	33.3	16	19
1BO9-06-08OG	G3/8"X19	3/4"X16		16.36X2.21	28.5	37.5	19	24
1BO9-06-10OG	G3/8"X19	7/8"X14		19.18X2.46	31	44	22	27
1BO9-08OG	G1/2"X14	3/4"X16		16.36X2.21	34.5	40	22	24
1BO9-08-10OG	G1/2"X14	7/8"X14		19.18X2.46	34.5	44	22	27

1BO9-08-12OG	G1/2"X14	1.1/16"X12		23.47X2.95	37.5	51	27	32
1BO9-10OG	G5/8"X14	7/8"X14		19.18X2.46	35	44	22	27
1BO9-12OG	G3/4"X14	1.1/16"X12		23.47X2.95	40	51	27	32
1BO9-12-08OG	G3/4"X14	3/4"X16		16.36X2.21	40	43	27	24
1BO9-12-10OG	G3/4"X14	7/8"X14		19.18X2.46	40	47	27	27
1BO9-12-16OG	G3/4"X14	1.5/16"X12		29.74X2.95	41	54.5	33	41
1BO9-16OG	G1"X11	1.5/16"X12		29.74X2.95	46	54.5	33	41
1BO9-16-12OG	G1"X11	1.1/16"X12		23.47X2.95	46	54.5	33	32
1BO9-16-20OG	G1"X11	1.5/8"X12		37.46X3.00	50.5	59.5	41	50
1BO9-20OG	G1.1/4"X11	1.5/8"X12		37.46X3.00	50.5	59.5	41	50
1BO9-20-16OG	G1.1/4"X11	1.5/16"X12		29.74X2.95	50.5	59.5	41	41
1BO9-20-24OG	G1.1/4"X11	1.7/8"X12		43.69X3.00	54.5	63	48	55
1BO9-24OG	G1.1/2"X11	1.7/8"X12		43.69X3.00	57.5	63	48	55

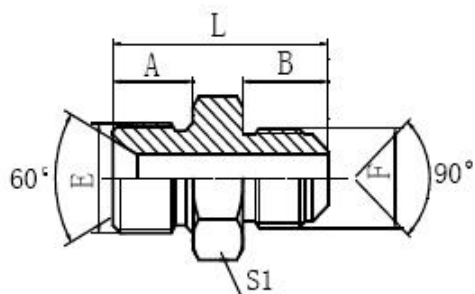

1BP

英管外螺纹 60°内锥/美制 SAE 外螺纹 90°外锥

BSP MALE 60° SEAT/SAE MALE 90° CONE

代号 P/N	螺纹 Thread		O形圈 O-RING		尺寸 DIMENSIONS			
	E	F		F END	A	B	L	S1
1BP-04	G1/4"X19	7/16"x20			12	12.7	31	19
1BP-04-06	G1/4"X19	5/8"x18			12	15.7	34	19
1BP-06	G3/8"X19	5/8"x18			13.5	15.7	37	22
1BP-06-10	G3/8"X19	7/8"x14			13.5	22.4	44	24
1BP-08	G1/2"X14	3/4"x16			16	19	45	27
1BP-10	G5/8"X14	7/8"x14			17.5	22.4	50	30

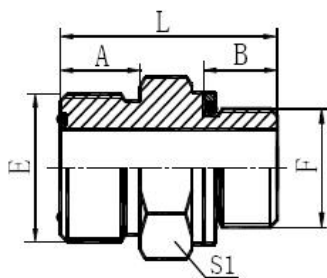

1FG

美制 ORFS 外螺纹平面/英管 O 形圈密封

ORFS MALE FLAT/BSP O-RING SEAL

代号 P/N	螺纹 Thread		O 形圈 O-RING		尺寸 DIMENSIONS			
	E	F	E END	F END	A	B	L	S1
1FG-04-02	9/16"x18	G1/8"x28	7.65X1.78	7.65X1.78	10	9.5	27.4	17
1FG-04	9/16"X18	G1/4"X19	7.65X1.78	10.77X2.62	10	10	26	19
1FG-04-06	9/16"X18	G3/8"X19	7.65X1.78	13.94X2.62	10	11.5	29.5	22
1FG-06	11/16"X16	G3/8"X19	9.25X1.78	13.94X2.62	11.2	11.5	30.5	22
1FG-06-04	11/16"X16	G1/4"X19	9.25X1.78	10.77X2.62	11.2	10	27.5	19
1FG-06-08	11/16"X16	G1/2"X14	9.25X1.78	17.12X2.62	11.2	14	35.5	27
1FG-08	13/16"X16	G1/2"X14	12.42X1.78	17.12X2.62	13	14	37	27
1FG-08-06	13/16"X16	G3/8"X19	12.42X1.78	13.94X2.62	13	11.5	32.5	22
1FG-08-12	13/16"X16	G3/4"X14	12.42X1.78	23.47X2.62	13	15.5	39.5	32
1FG-10-06	1"X14	G3/8"X19	15.6X1.78	13.94X2.62	15.5	11.5	37	22
1FG-10-08	1"x14	G1/2"x14	15.6X1.78	17.12X2.62	15.5	14	41.1	27
1FG-10-12	1"X14	G3/4"X14	15.6X1.78	23.47X2.62	15.5	15.5	42	32
1FG-12-08	1.3/16"X12	G1/2"X14	18.77X1.78	17.12X2.62	17	14	42	27
1FG-12	1.3/16"x12	G3/4"x14	18.77X1.78	23.47X2.62	17	15.5	45.6	32
1FG-12-16	1.3/16"X12	G1"X11	18.77X1.78	29.74X3.53	17	18	48	41
1FG-16	1.7/16"X12	G1"X11	23.52X1.78	29.74X3.53	17.5	18	48.5	41
1FG-20	1.11/16"X12	G1.1/4"X11	29.87X1.78	37.69X3.53	17.5	20	52.5	50
1FG-20-16	1.11/16"X12	G1"X11	29.87X1.78	29.74X3.53	17.5	18	48.5	46
1FG-24	2"x12	G1.1/2"x11	37.82X1.78	44.04X3.53	17.5	21.5	57.1	55

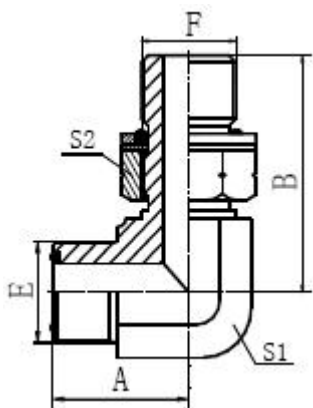

1FG9-OG

90°美制 ORFS 外螺纹/英管外螺纹带 O 形圈

90° ORFS MALE/BSP MALE WITH O-Ring

代号 P/N	螺纹 Thread		O 形圈 O-RING		尺寸 DIMENSIONS			
	E	F	E END	F END	A	B	L	S1
1FG9-04OG	9/16"X18	G1/4"X19	7.65X1.78	10.77X2.62	23	31.3	14	19
1FG9-04-02OG	9/16"X18	G1/8"X28	7.65X1.78	7.65X1.78	23	29	14	14
1FG9-04-06OG	9/16"X18	G3/8"X19	7.65X1.78	13.94X2.62	24	35.8	16	22
1FG9-06OG	11/16"X16	G3/8"X19	9.25X1.78	13.94X2.62	27	36.8	19	22
1FG9-06-04OG	11/16"X16	G1/4"X19	9.25X1.78	10.77X2.62	27	33.5	19	19
1FG9-06-08OG	11/16"X16	G1/2"X14	9.25X1.78	17.12X2.62	29	43.2	22	27
1FG9-08OG	13/16"X16	G1/2"X14	12.42X1.78	17.12X2.62	31	43.2	22	27
1FG9-08-06OG	13/16"X16	G3/8"X19	12.42X1.78	13.94X2.62	31	39.5	22	22
1FG9-10-06OG	1"X14	G3/8"X19	15.6X1.78	13.94X2.62	36.5	42.5	27	22
1FG9-10-08OG	1"X14	G1/2"X14	15.6X1.78	17.12X2.62	36.5	46.5	27	27
1FG9-10-12OG	1"X14	G3/4"X14	15.6X1.78	23.47X2.62	36.5	49.3	27	32
1FG9-12OG	1.3/16"X12	G3/4"X14	18.77X1.78	23.47X2.62	40.3	52	30	32
1FG9-12-08OG	1.3/16"X12	G1/2"X14	18.77X1.78	17.12X2.62	40.3	48.5	30	27
1FG9-12-16OG	1.3/16"X12	G1"X11	18.77X1.78	29.74X3.53	42.5	53	33	41
1FG9-16OG	1.7/16"X12	G1"X11	23.52X1.78	29.74X3.53	44.5	56	36	41
1FG9-16-12OG	1.7/16"X12	G3/4"X14	23.52X1.78	23.47X2.62	44.5	56	36	32
1FG9-16-20OG	1.7/16"X12	G1.1/4"X11	23.52X1.78	37.69X3.53	47.6	58	41	50

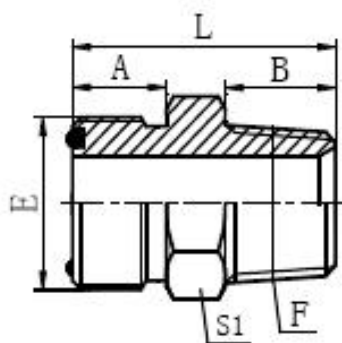

1FT-SP

美制 ORFS 外螺纹/英锥管外螺纹

ORFS MALE/BSPT MALE

代号 P/N	螺纹 Thread		O 形圈 O-RING		尺寸 DIMENSIONS			
	E	F	E END	F END	A	B	L	S1
1FT-04SP	9/16"X18	R1/4"X19	7.65X1.78		9.8	14.5	30	17
1FT-06SP	11/16"X16	R3/8"X19	9.25X1.78		11.2	15	31.5	19
1FT-08SP	13/16"X16	R1/2"X14	12.42X1.78		12.8	20	40	22
1FT-10-08SP	1"X14	R1/2"X14	15.6X1.78		15.5	20	45.5	27
1FT-12SP	1.3/16"X12	R3/4"X14	18.77X1.78		17	20	47	32
1FT-12-16SP	1.3/16"X12	R1"X11	18.77X1.78		17	25.5	53.5	36
1FT-16SP	1.7/16"X12	R1"X11	23.52X1.78		17.5	25.5	52.5	38
1FT-20SP	1.11/16"X12	R1.1/4"X11	29.87X1.78		17.5	26.5	57	46
1FT-24SP	2"X12	R1.1/2"X11	37.82X1.78		17.5	26.5	59	55

1JB-WD

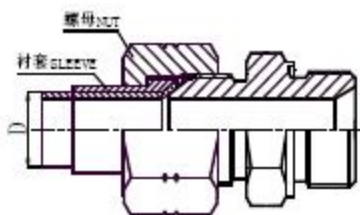
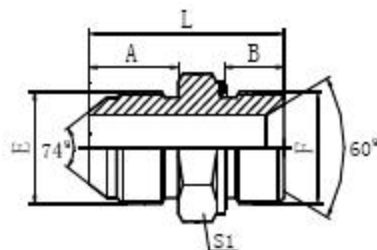

JIC 外螺纹 74°外锥/英管外螺纹胶垫密封

JIC MALE 74° CONE/BSP MALE

CAPTIVE SEAL

代号 P/N	螺纹 Thread		胶 垫 CAPTIVE		尺寸 DIMENSIONS			
	E	F	E END	F END	A	B	L	S1
1JB-04WD	7/16"X20	G1/4"X19		WD-B04	14	12	34	19
1JB-04-02WD	7/16"X20	G1/8"X28		WD-B02	14	8	29.5	14
1JB-04-06WD	7/16"X20	G3/8"X19		WD-B06	14	12	34.5	22
1JB-04-08WD	7/16"X20	G1/2"X14		WD-B08	14	14	41	27
1JB-05-04WD	1/2"X20	G1/4"X19		WD-B04	14	12	34	19
1JB-05-06WD	1/2"X20	G3/8"X19		WD-B06	14	12	34.5	22
1JB-06WD	9/16"X18	G3/8"X19		WD-B06	14.1	12	34.5	22
1JB-06-02WD	9/16"X18	G1/8"X28		WD-B02	14.1	8	29.5	17
1JB-06-04WD	9/16"X18	G1/4"X19		WD-B04	14.1	12	34	19
1JB-06-08WD	9/16"X18	G1/2"X14		WD-B08	14.1	14	41	27
1JB-08WD	3/4"X16	G1/2"X14		WD-B08	16.7	14	43.5	27
1JB-08-04WD	3/4"X16	G1/4"X19		WD-B04	16.7	12	37	22
1JB-08-06WD	3/4"X16	G3/8"X19		WD-B06	16.7	12	37.5	22
1JB-08-12WD	3/4"X16	G3/4"X14		WD-B12	16.7	16	45	32
1JB-10-06WD	7/8"X14	G3/8"X19		WD-B06	19.3	12	41.5	24
1JB-10-08WD	7/8"X14	G1/2"X14		WD-B08	19.3	14	46.5	27
1JB-10-12WD	7/8"X14	G3/4"X14		WD-B12	19.3	16	47.5	32
1JB-12WD	1.1/16"X1	G3/4"X14		WD-B12	21.9	16	50	32

1JB-12-06WD	1.1/16"X1	G3/8"X19		WD-B06	21.9	12	46	30
1JB-12-08WD	1.1/16"X1	G1/2"X14		WD-B08	21.9	14	48.5	30
1JB-12-16WD	1.1/16"X1	G1"X11		WD-B16	21.9	18	56	41
1JB-12-20WD	1.1/16"X1	G1.1/4"X11		WD-B20	21.9	20	60	50
1JB-16WD	1.5/16"X1	G1"X11		WD-B16	23.1	18	57	41
1JB-16-12WD	1.5/16"X1	G3/4"X14		WD-B12	23.1	16	53	36
1JB-16-20WD	1.5/16"X1	G1.1/4"X11		WD-B20	23.1	20	61	50
1JB-20WD	1.5/8"X12	G1.1/4"X11		WD-B20	24.3	20	62	50
1JB-20-16WD	1.5/8"X12	G1"X11		WD-B16	24.3	18	58	46
1JB-20-24WD	1.5/8"X12	G1.1/2"X11		WD-B24	24.3	22	64	55
1JB-24WD	1.7/8"X12	G1.1/2"X11		WD-B24	27.5	22	67.5	55
1JB-24-20WD	1.7/8"X12	G1.1/4"X11		WD-B20	27.5	20	65.5	50
1JB-32WD	2.1/2"X12	G/2"X11		WD-B32	34	20	73	75

Note: Nut and sleeve should be ordered separately. The nut NB200 and sleeve NB500 is suitable for metric tube, the nut NB200 and sleeve NB300 is suitable for inch tube.

1JG

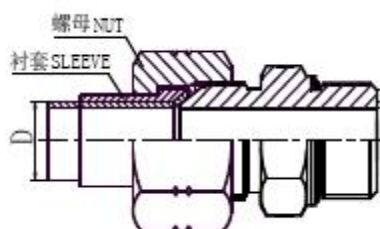
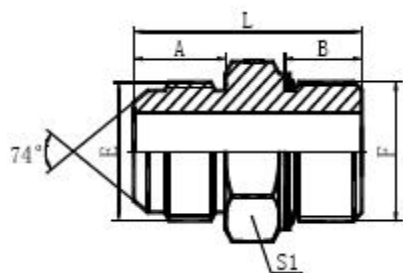

JIC 外螺纹 74°外锥/英管外螺纹

带 O 形圈

JIC MALE 74° CONE/BSP MALE

WITH O-RING

代号 P/N	螺纹 Thread		O 形圈 O-Ring		尺寸 DIMENSIONS			
	E	F	E END	F END	A	B	L	S1
1JG-04	7/16"X20	G1/4"X19		10.77X2.62	14	10	32	19
1JG-04-02	7/16"X20	G1/8"X28		7.65X1.78	14	9.5	31	14
1JG-04-06	7/16"X20	G3/8"X19		13.94X2.62	14	11.5	34	22
1JG-04-08	7/16"X20	G1/2"X14		17.12X2.62	14	14	39	27
1JG-05-02	1/2"X20	G1/8"X28		7.65X1.78	14	9.5	31	14
1JG-05-04	1/2"X20	G1/4"X19		10.77X2.62	14	10	32	19
1JG-05-06	1/2"X20	G3/8"X19		13.94X2.62	14	11.5	36	22
1JG-05-08	1/2"X20	G1/2"X14		17.12X2.62	14	14	39	27
1JG-05-12	1/2"X20	G3/4"X14		23.47X2.62	14	15.5	43	32
1JG-06	9/16"X18	G3/8"X19		13.94X2.62	14.1	11.5	34	22
1JG-06-04	9/16"X18	G1/4"X19		10.77X2.62	14.1	10	31	19
1JG-06-08	9/16"X18	G1/2"X14		17.12X2.62	14.1	14	39	27
1JG-08	3/4"X16	G1/2"X14		17.12X2.62	16.7	14	42	27
1JG-08-04	3/4"X16	G1/4"X19		10.77X2.62	16.7	10	35	22
1JG-08-06	3/4"X16	G3/8"X19		13.94X2.62	16.7	11.5	37	22
1JG-08-12	3/4"X16	G3/4"X14		23.47X2.62	16.7	15.5	44	32
1JG-10-06	7/8"X14	G3/8"X19		13.94X2.62	19.3	11.5	39.5	24
1JG-10-08	7/8"X14	G1/2"X14		17.12X2.62	19.3	14	44.5	27
1JG-10-12	7/8"X14	G3/4"X14		23.47X2.62	19.3	15.5	48.5	32

1JG-12	1.1/16"X1	G3/4"X14		23.47X2.62	22	15.5	49.5	32
1JG-12-06	1.1/16"X1	G3/8"X19		13.94X2.62	22	11.5	46.5	30
1JG-12-08	1.1/16"X1	G1/2"X14		17.12X2.62	22	14	49	30
1JG-12-16	1.1/16"X1	G1"X11		29.74X3.53	22	18	54	41
1JG-16	1.5/16"X1	G1"X11		29.74X3.53	23	18	55	41
1JG-16-12	1.5/16"X1	G3/4"X14		23.47X2.62	23	15.5	52.5	36
1JG-16-20	1.5/16"X1	G1.1/4"X11		37.69X3.53	23	20	58	50
1JG-16-24	1.5/16"X1	G1.1/2"X11		44.04X3.53	23	21.5	59.5	55
1JG-20	1.5/8"X12	G1.1/4"X11		37.69X3.53	24.3	20	59.5	50
1JG-20-16	1.5/8"X12	G1"X11		29.74X3.53	24.3	18	58	45
1JG-24	1.7/8"X12	G1.1/2"X11		44.04X3.53	27.5	21.5	64	55
1JG-24-16	1.7/8"X12	G1"X11		29.74X3.53	27.5	18	60.5	50
1JG-24-20	1.7/8"X12	G1.1/4"X11		37.69X3.53	27.5	20	65.5	50

Note: Nut and sleeve should be ordered separately. The nut NB200 and sleeve NB500 is suitable for metric tube, the nut NB200 and sleeve NB300 is suitable for inch tube.

1JG4-OG

45° JIC 外螺纹 74°外锥/英管外螺纹带 O
形圈

45° JIC MALE 74° CONE/BSP MALE
WITH O-RING

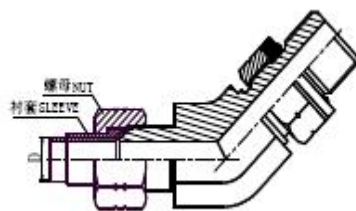
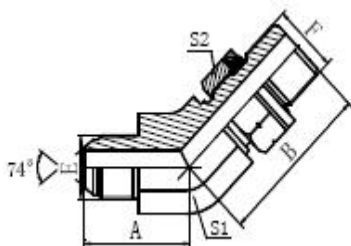

代号 P/N	螺纹 Thread		O 形圈 O-Ring		尺寸 DIMENSIONS			
	E	F	E END	F END	A	B	S1	S2
1JG4-04OG	7/16"X20	G1/4"X19		10.77X2.62	21	28	14	19
1JG4-05-04OG	1/2"X20	G1/4"X19		10.77X2.62	21	28	14	19
1JG4-06-04OG	9/16"X18	G1/4"X19		10.77X2.62	22	28	14	19
1JG4-06OG	9/16"X18	G3/8"X19		13.94X2.62	23	32	19	22
1JG4-08-06OG	3/4"X16	G3/8"X19		13.94X2.62	25.8	32	19	22
1JG4-08OG	3/4"X16	G1/2"X14		17.12X2.62	27.5	36	22	27
1JG4-10-08OG	7/8"X14	G1/2"X14		17.12X2.62	29.5	38	22	27
1JG4-10OG	7/8"X14	G5/8"X14		19.18X2.46	29.5	38	22	30
1JG4-12-10OG	1.1/16"X12	G5/8"X14		19.18X2.46	34	38.5	27	30
1JG4-12OG	1.1/16"X12	G3/4"X14		23.47X2.62	34	42	27	32
1JG4-12-16OG	1.1/16"X12	G1"X11		29.74X3.53	37.5	44	33	41
1JG4-16-12OG	1.5/16"X12	G3/4"X14		23.47X2.62	38	44	33	32
1JG4-16OG	1.5/16"X12	G1"X11		29.74X3.53	38	44	33	41
1JG4-20OG	1.5/8"X12	G1.1/4"X11		37.69X3.53	43	47.5	41	50

Note: Nut and sleeve should be ordered separately. The nut NB200 and sleeve NB500 is suitable for metric tube, the nut NB200 and sleeve NB300 is suitable for inch tube.

1JG9-OG

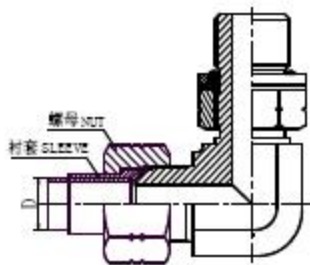
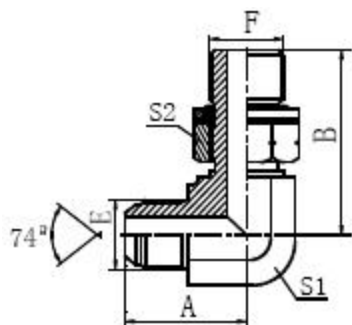

90° JIC 外螺纹 74°外锥/英管外螺纹带 O 形圈

90° JIC MALE 74° CONE/BSP MALE
WITH O-RING

代号 P/N	螺纹 Thread		O 形圈 O-Ring		尺寸 DIMENSIONS			
	E	F	E END	F END	A	B	S1	S2
1JG9-04OG	7/16"X20	G1/4"X19		10.77X2.62	26.6	31.3	14	19
1JG9-04-02OG	7/16"X20	G1/8"X28		7.65X1.78	24.5	26.2	11	14
1JG9-04-06OG	7/16"X20	G3/8"X19		13.94X2.62	27.5	36.8	16	22
1JG9-05-04OG	1/2"X20	G1/4"X19		10.77X2.62	26.5	31.8	14	19
1JG9-05-06OG	1/2"X20	G3/8"X19		13.94X2.62	27.5	35.8	16	22
1JG9-05-08OG	1/2"X20	G1/2"X14		17.12X2.62	31.5	43.2	22	27
1JG9-06OG	9/16"X18	G3/8"X19		13.94X2.62	28.5	35.8	16	22
1JG9-06-04OG	9/16"X18	G1/4"X19		10.77X2.62	26.9	31.3	14	19
1JG9-06-08OG	9/16"X18	G1/2"X14		17.12X2.62	32.5	43.2	22	27
1JG9-08OG	3/4"X16	G1/2"X14		17.12X2.62	34.8	43.2	22	27
1JG9-08-04OG	3/4"X16	G1/4"X19		10.77X2.62	32	33.5	19	19
1JG9-08-06OG	3/4"X16	G3/8"X19		13.94X2.62	32	36.8	19	22
1JG9-08-12OG	3/4"X16	G3/4"X14		23.47X2.62	37.9	49.3	27	32
1JG9-10OG	7/8"X14	G5/8"X14		19.18X2.46	36.8	44.5	22	30
1JG9-10-04OG	7/8"X14	G1/4"X19		10.77X2.62	36.8	36	22	19
1JG9-10-06OG	7/8"X14	G3/8"X19		13.94X2.62	37.8	39.2	22	22
1JG9-10-08O	7/8"X14	G1/2"X14		17.12X2.62	37.8	43.2	22	27
1JG9-10-12OG	7/8"X14	G3/4"X14		23.47X2.62	41	49.3	27	32

1JG9-12OG	1.1/16"X1	G3/4"X14		23.47X2.62	44.2	49.3	27	32
1JG9-12-08OG	1.1/16"X1	G1/2"X14		17.12X2.62	44.2	46.5	27	27
1JG9-12-16OG	1.1/16"X1	G1"X11		29.74X3.53	48	53	33	41
1JG9-16OG	1.5/16"X1	G1"X11		29.74X3.53	49	53	33	41
1JG9-16-12OG	1.5/16"X1	G3/4"X14		23.47X2.62	49	53	33	32
1JG9-16-20OG	1.5/16"X1	G1.1/4"X11		37.69X3.53	53.8	58	41	50
1JG9-20OG	1.5/8"X12	G1.1/4"X11		37.69X3.53	55.5	58	41	50
1JG9-20-16OG	1.5/8"X12	G1"X11		29.74X3.53	55.5	58	41	41
1JG9-24-16OG	1.7/8"X12	G1"X11		29.74X3.53	62.5	63	48	41
1JG9-24-20OG	1.7/8"X12	G1.1/4"X11		37.69X3.53	62.5	63	48	50
1JG9-24OG	1.7/8"X12	G1.1/2"X11		44.04X3.53	62.5	63	48	55

Note: Nut and sleeve should be ordered separately. The nut NB200 and sleeve NB500 is suitable for metric tube, the nut NB200 and sleeve NB300 is suitable for inch tube.

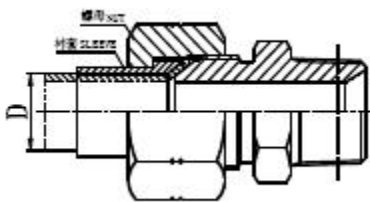
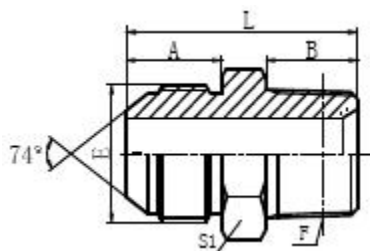

1JT-SP

JIC 外螺纹 74°外锥/英锥管外螺纹

JIC MALE 74 ° CONE/BSPT

MALE

代号 P/N	螺纹 Thread		O 形圈 O-Ring		尺寸 DIMENSIONS			
	E	F	E END	F END	A	B	L	S1
1JT-04SP	7/16"X20	R1/4"X19			14	14.5	34.5	17
1JT-04-02SP	7/16"X20	R1/8"X28			14	10	30	12
1JT-04-06SP	7/16"X20	R3/8"X19			14	15	35	19
1JT-04-08SP	7/16"X20	R1/2"X14			14	20	41	24
1JT-05-02SP	1/2"X20	R1/8"X28			14	10.5	30.5	14
1JT-05-04SP	1/2"X20	R1/4"X19			14	14.5	34	17
1JT-05-06SP	1/2"X20	R3/8"X19			14	15	35	19
1JT-06SP	9/16"X18	R3/8"X19			14.1	15	34	19
1JT-06-02SP	9/16"X18	R1/8"X28			14.1	10.5	30.5	17
1JT-06-04SP	9/16"X18	R1/4"X19			14.1	14.5	34	17
1JT-06-08SP	9/16"X18	R1/2"X14			14.1	20	41	22
1JT-06-12SP	9/16"X18	R3/4"X14			14.1	20	43.5	30
1JT-08SP	3/4"X16	R1/2"X14			16.7	20	44.5	22
1JT-08-04SP	3/4"X16	R1/4"X19			16.7	14.5	39	22
1JT-08-06SP	3/4"X16	R3/8"X19			16.7	15	39	22
1JT-08-12SP	3/4"X16	R3/4"X14			16.7	20	46	30
1JT-08-16SP	3/4"X16	R1"X11			16.7	25.5	52	36
1JT-10-08SP	7/8"X14	R1/2"X14			19.3	20	46.5	24
1JT-12SP	1.1/16"X1	R3/4"X14			21.9	20	51	30

1JT-12-06SP	1.1/16"X1	R3/8"X19			21.9	15.5	47	30
1JT-12-08SP	1.1/16"X1	R1/2"X14			21.9	20	51	30
1JT-12-16SP	1.1/16"X1	R1"X11			21.9	25.5	57.5	36
1JT-12-20SP	1.1/16"X1	R1.1/4"X11			21.9	26.5	61.5	46
1JT-14-12SP	1.3/16"X1	R3/4"X14			22.6	20	52.5	32
1JT-14-16SP	1.3/16"X1	R1"X11			22.6	25.5	58.5	36
1JT-16SP	1.5/16"X1	R1"X11			23.1	25.5	59	36
1JT-16-08SP	1.5/16"X1	R1/2"X14			23.1	20	53	36
1JT-16-12SP	1.5/16"X1	R3/4"X14			23.1	20	53	36
1JT-16-20SP	1.5/16"X1	R1.1/4"X11			23.1	26.5	61.5	46
1JT-16-24SP	1.5/16"X1	R1.1/2"X11			23.1	26.5	64.5	50
1JT-20SP	1.5/8"X12	R1.1/4"X11			24.3	26.5	63	46
1JT-20-12SP	1.5/8"X12	R3/4"X14			24.3	20	57	46
1JT-20-16SP	1.5/8"X12	R1"X11			24.3	25.5	62.5	46
1JT-20-24SP	1.5/8"X12	R1.1/2"X11			24.3	26.5	66.5	50
1JT-24SP	1.7/8"X12	R1.1/2"X11			27.5	26.5	69.5	50
1JT-24-16SP	1.7/8"X12	R1"X11			27.5	25.5	67.5	50
1JT-24-20SP	1.7/8"X12	R1.1/4"X11			27.5	26.5	67.5	50
1JT-24-32SP	1.7/8"X12	R2"X11			27.5	30	74.5	65
1JT-32SP	2.1/2"X12	R2"X11			33.9	30	80	65
1JT-32-24SP	2.1/2"X12	R1.1/2"X11			33.9	26.5	77.5	65

Note: Nut and sleeve should be ordered separately. The nut NB200 and sleeve NB500 is suitable for metric tube, the nut NB200 and sleeve NB300 is suitable for inch tube.

1JT4-SP

45° JIC 外螺纹 74°外锥/英锥管外螺
纹

45° JIC MALE 74° CONE/BSPT

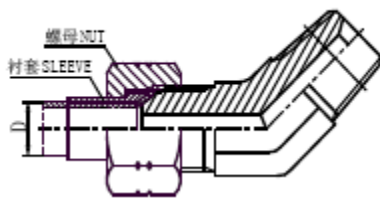
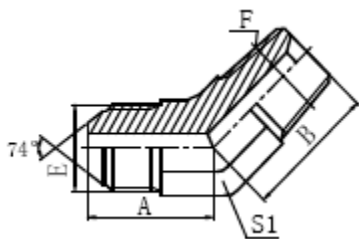

MALE

代号 P/N	螺纹 Thread		O 形圈 O-Ring		尺寸 DIMENSIONS			
	E	F	E END	F END	A	B	S1	
1JT4-04-02SP	7/16"X20	R1/8"X28			21.5	17	11	
1JT4-04SP	7/16"X20	R1/4"X19			22.3	21	14	
1JT4-04-06SP	7/16"X20	R3/8"X19			22.8	23	16	
1JT4-04-08SP	7/16"X20	R1/2"X14			24.5	29.5	22	
1JT4-05-02SP	1/2"X20	R1/8"X28			21.5	17.5	14	
1JT4-05-04SP	1/2"X20	R1/4"X19			22.3	21	14	
1JT4-05-06SP	1/2"X20	R3/8"X19			22.8	23	16	
1JT4-06-02SP	9/16"X18	R1/8"X28			22.8	18.2	14	
1JT4-06-04SP	9/16"X18	R1/4"X19			22.8	21	14	
1JT4-06SP	9/16"X18	R3/8"X19			22	23	16	
1JT4-06-08SP	9/16"X18	R1/2"X14			25	29.5	22	
1JT4-06-12SP	9/16"X18	R3/4"X14			26.5	30.5	27	
1JT4-08-04SP	3/4"X16	R1/4"X19			26.8	22	19	
1JT4-08-06SP	3/4"X16	R3/8"X19			26.8	24	19	
1JT4-08SP	3/4"X16	R1/2"X14			28	29.5	22	
1JT4-08-12SP	3/4"X16	R3/4"X14			29	30.5	27	
1JT4-10-06SP	7/8"X14	R3/8"X19			31	25	22	
1JT4-10-08SP	7/8"X14	R1/2"X14			31	29.5	22	
1JT4-10-12SP	7/8"X14	R3/4"X14			32	30.5	27	

1JT4-10-16SP	7/8"X14	R1"X11			34	38	33	
1JT4-12-08SP	1.1/16"X1	R1/2"X14			35.5	30	27	
1JT4-12SP	1.1/16"X1	R3/4"X14			35.5	30.5	27	
1JT4-12-16SP	1.1/16"X1	R1"X11			37.5	38	33	
1JT4-16-12SP	1.5/16"X1	R3/4"X14			38.5	32.5	33	
1JT4-16SP	1.5/16"X1	R1"X11			38.5	38	33	
1JT4-16-20SP	1.5/16"X1	R1.1/4"X11			42	43	41	
1JT4-20-16SP	1.5/8"X12	R1"X11			43	42	41	
1JT4-20SP	1.5/8"X12	R1.1/4"X11			43	43	41	
1JT4-20-24SPP	1.5/8"X12	R1.1/2"X11			46	47.5	48	
1JT4-24-16SP	1.7/8"X12	R1"X11			49	44.5	48	
1JT4-24-20SP	1.7/8"X12	R1.1/4"X11			49	45.5	48	
1JT4-24SP	1.7/8"X12	R1.1/2"X11			49	47.5	48	

Note: Nut and sleeve should be ordered separately. The nut NB200 and sleeve NB500 is suitable for metric tube, the nut NB200 and sleeve NB300 is suitable for inch tube.

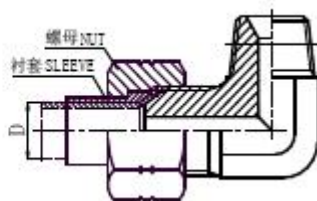
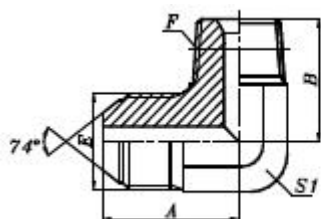

1JT9-SP

90° JIC 外螺纹 74°外锥/英锥管外螺纹

90° JIC MALE 74°/BSPT MALE

代号 P/N	螺纹 Thread		O 形圈 O-Ring		尺寸 DIMENSIONS			
	E	F	E END	F END	A	B	S1	
1JT9-04SP	7/16"X20	R1/4"X19			26.6	25.5	14	
1JT9-04-02SP	7/16"X20	R1/8"X28			24.5	21	11	
1JT9-04-06SP	7/16"X20	R3/8"X19			27.5	28	16	
1JT9-04-08SP	7/16"X20	R1/2"X14			31.5	36	22	
1JT9-05-02SP	1/2"X20	R1/8"X28			26.6	23.5	14	
1JT9-05-04SP	1/2"X20	R1/4"X19			26.6	25.5	14	
1JT9-05-06SP	1/2"X20	R3/8"X19			27.5	28	16	
1JT9-06SP	9/16"X18	R3/8"X19			28.5	28.5	16	
1JT9-06-02SP	9/16"X18	R1/8"X28			26.9	23.5	14	
1JT9-06-04SP	9/16"X18	R1/4"X19			26.9	25.5	14	
1JT9-06-08SP	9/16"X18	R1/2"X14			32	36	22	
1JT9-08SP	3/4"X16	R1/2"X14			34.8	36	22	
1JT9-08-04SP	3/4"X16	R1/4"X19			32	28	19	
1JT9-08-06SP	3/4"X16	R3/8"X19			32	30.5	19	
1JT9-08-12SP	3/4"X16	R3/4"X14			37.9	43.5	27	
1JT9-08-16SP	3/4"X16	R1"X11			41.5	50	33	
1JT9-10-06SP	7/8"X14	R3/8"X19			38	32	22	
1JT9-10-08SP	7/8"X14	R1/2"X14			37.8	36	22	
1JT9-10-12SP	7/8"X14	R3/4"X14			41	43.5	27	
1JT9-10-16SP	7/8"X14	R1"X11			46	50	33	

1JT9-12SP	1.1/16"X1	R3/4"X14			44.2	43.5	27	
1JT9-12-08SP	1.1/16"X1	R1/2"X14			44.2	40	27	
1JT9-12-16SP	1.1/16"X1	R1"X11			47.8	50	33	
1JT9-16SP	1.5/16"X1	R1"X11			49	50	33	
1JT9-16-12SP	1.5/16"X1	R3/4"X14			49	47.5	33	
1JT9-16-20SP	1.5/16"X1	R1.1/4"X11			54	56.5	41	
1JT9-20SP	1.5/8"X12	R1.1/4"X11			55.5	56.5	41	
1JT9-20-16SP	1.5/8"X12	R1"X11			55.5	56.5	41	
1JT9-20-24SP	1.5/8"X12	R1.1/2"X11			63	64	50	
1JT9-24SP	1.7/8"X12	R1.1/2"X11			62.5	62.5	48	
1JT9-24-16SP	1.7/8"X12	R1"X11			62.5	60	48	
1JT9-24-32SP	1.7/8"X12	R2"X11			74.5	67	63	
1JT9-32SP	2.1/2"X12	R2"X11			75.4	67	63	

Note: Nut and sleeve should be ordered separately. The nut NB200 and sleeve NB500 is suitable for metric tube, the nut NB200 and sleeve NB300 is suitable for inch tube.

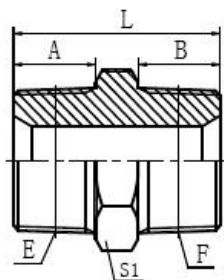

1NT-SP

布锥管外螺纹/英锥管外螺纹

NPT MALE/BSPT MALE

代号 P/N	螺纹 Thread		O 形圈 O-Ring		尺寸 DIMENSIONS			
	E	F	E END	F END	A	B	L	S1
1NT-02SP	Z1/8"X27	R1/8"X28			10.5	10	26.5	12
1NT-02-04SP	Z1/8"X27	R1/4"X19			10.5	14.5	31	17
1NT-04SP	Z1/4"X18	R1/4"X19			15	14.5	35	17
1NT-04-02SP	Z1/4"X18	R1/8"X28			15	10	31	17
1NT-04-06SP	Z1/4"X18	R3/8"X19			15	15	36	19
1NT-06SP	Z3/8"X18	R3/8"X19			16	15	36	19
1NT-06-04SP	Z3/8"X18	R1/4"X19			16	14.5	36.5	19
1NT-06-08SP	Z3/8"X18	R1/2"X14			16	20	44	22
1NT-08SP	Z1/2"X14	R1/2"X14			19.5	20	47.5	22
1NT-08-06SP	Z1/2"X14	R3/8"X19			19.5	15	42.5	22
1NT-08-12SP	Z1/2"X14	R3/4"X14			19.5	20	49.5	30
1NT-12SP	Z3/4"X14	R3/4"X14			19.5	20	49.5	30
1NT-12-08SP	Z3/4"X14	R1/2"X14			19.5	20	49.5	30
1NT-12-16SP	Z3/4"X14	R1"X11			19.5	25.5	56	36
1NT-16SP	Z1"X11.5	R1"X11			25.5	25.5	62	36
1NT-16-12SP	Z1"X11.5	R3/4"X14			25.5	20	56.5	36
1NT-16-20SP	Z1"X11.5	R1.1/4"X11			25.5	26.5	65	46
1NT-20SP	Z1.1/4"X11.5	R1.1/4"X11			26.5	26.5	66	46
1NT-20-16SP	Z1.1/4"X11.5	R1"X11			26.5	25.5	64	46
1NT-20-24SP	Z1.1/4"X11.5	R1.1/2"X11			26.5	26.5	68	50

1NT-24SP	Z1.1/2"X11.5	R1.1/2"X11			27.5	26.5	69	50
1NT-24-32SP	Z1.1/2"X11.5	R2"X11			27.5	30	74.5	65
1NT-32SP	Z2"X11.5	R2"X11			27.5	30	74.5	65

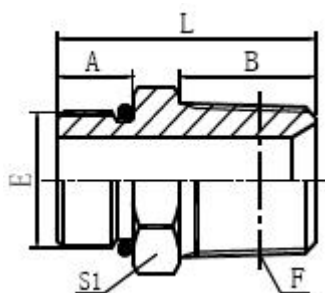

1OT-SP

SAE 外螺纹带 O 形圈/英锥管外螺纹

SAE O-RING BOSS/BSPT MALE

代号 P/N	螺纹 Thread		O 形圈 O-Ring		尺寸 DIMENSIONS			
	E	F	E END	F END	A	B	L	S1
1OT-04SP	7/16"X20	R1/4"X19	8.92X1.83		9.14	14.5	29.5	17
1OT-06SP	9/16"X18	R3/8"X19	11.89X1.98		9.93	15	30.5	19
1OT-06-04S	9/16"X18	R1/4"X19	11.89X1.98		9.93	14.5	30	19
1OT-08SP	3/4"X16	R1/2"X14	16.36X2.21		11.13	20	38	22
1OT-12SP	1.1/16"X12	R3/4"X14	23.47X2.95		15.09	20	46	32
1OT-16SP	1.5/16"X12	R1"X11	29.74X2.95		15.09	25.5	51	38

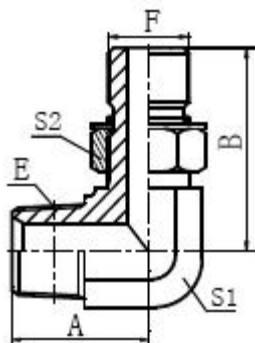

1TO9-OG/SP

90°英锥管外螺纹/美制 SAE 外螺纹 O 形圈

90° BSPT MALE/SAE O-RING BOSS

代号 P/N	螺纹 Thread		O 形圈 O-Ring		尺寸 DIMENSIONS			
	E	F		F END	A	B	S1	S2
1TO9-04OG/SP	R1/4"X19	7/16"X20		8.92X1.83	26	31	14	17
1TO9-04-06OG/SP	R1/4"X19	9/16"X18		11.89X1.98	26	31.8	14	19
1TO9-06OG/SP	R3/8"X19	9/16"X18		11.89X1.98	28.5	33.3	16	19
1TO9-06-08OG/SP	R3/8"X19	3/4"X16		16.36X2.21	31	37	19	24
1TO9-06-10OG/SP	R3/8"X19	7/8"X14		19.18X2.46	33.5	44	22	27
1TO9-08OG/SP	R1/2"X14	3/4"X16		16.36X2.21	37	40.5	22	24
1TO9-08-10OG/SP	R1/2"X14	7/8"X14		19.18X2.46	38	44	22	27
1TO9-08-12OG/SP	R1/2"X14	1.1/16"X12		23.47X2.95	41	51	27	32
1TO9-12-10OG/SP	R3/4"X14	7/8"X14		19.18X2.46	43	47	27	27
1TO9-12OG/SP	R3/4"X14	1.1/16"X12		23.47X2.95	43.5	51	27	32
1TO9-12-16OG/SP	R3/4"X14	1.5/16"X12		29.74X2.95	47.5	54.5	33	41
1TO9-16OG/SP	R3/4"X14	1.5/16"X12		29.74X2.95	50	54.5	33	41
1TO9-20OG/SP	R1.1/4"X11	1.5/8"X12		37.46X3.00	56.5	59.5	41	50
1TO9-16-20OG/SP	R1"X11	1.5/8"X12		37.46X3.00	55.5	59	41	50

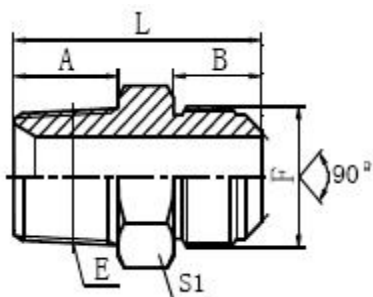

1TP-SP

英锥管外螺纹/美制 SAE 外螺纹 90°外锥

BSPT MALE/SAE MALE 90° CONE

代号 P/N	螺纹 Thread		O 形圈 O-Ring		尺寸 DIMENSIONS			
	E	F		F END	A	B	L	S1
1TP-04SP	R1/4"X19	7/16"X20			14.5	12.7	33	17
1TP-04-06SP	R1/4"X19	5/8"X18			14.5	15.7	36	17
1TP-06SP	R3/8"X19	5/8"X18			15	15.7	37	19
1TP-06-10SP	R3/8"X19	7/8"X14			15	22.4	45.5	24
1TP-08SP	R1/2"X14	3/4"X16			20	19	46.5	22
1TP-08-06SP	R1/2"X14	5/8"X18			20	15.7	43.5	22
1TP-08-10SP	R1/2"X14	7/8"X14			20	22.4	50	24
1TP-08-12SP	R1/2"X14	1.1/16"X14			20	25.4	55	30

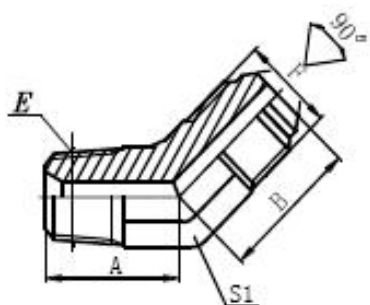

1TP4-SP

45°英锥管外螺纹/美制 SAE 外螺纹 90°外锥

45° BSPT MALE/SAE MALE 90° CONE

代号 P/N	螺纹 Thread		O 形圈 O-Ring		尺寸 DIMENSIONS			
	E	F		F END	A	B	S1	
1TP4-04-06SP	R1/4"X19	5/8"X18			21	25	16	
1TP4-06SP	R3/8"X19	5/8"X18			23	25	16	

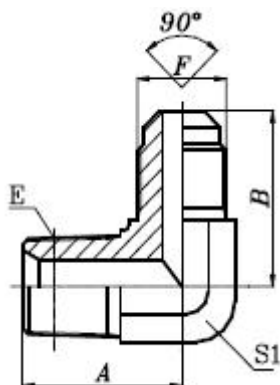

1TP9-SP

90°英锥管外螺纹/美制 SAE 外螺纹 90°外锥

90° BSPT MALE/SAE MALE 90° CONE

代号 P/N	螺纹 Thread		O 形圈 O-Ring		尺寸 DIMENSIONS			
	E	F		F END	A	B	S1	
1TP9-04-06SP	R1/4"X19	5/8"X18			26.5	30	16	
1TP9-06SP	R3/8"X19	5/8"X18			28.5	30	16	
1TP9-08-06SP	R1/2"X14	5/8"X18			36	33.5	22	

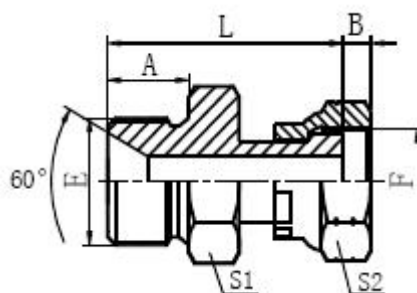

2BF

英管外螺纹 60°内锥/美制 ORFS 内螺纹

BSP MALE 60° SEAT/ORFS FEMALE

代号 P/N	螺纹 Thread		O 形圈 O-Ring		尺寸 DIMENSIONS				
	E	F		F END	A	B	L	S1	S2
2BF-04	G1/4"X19	9/16"X18			12	8.5	33.5	19	19
2BF-04-06	G1/4"X19	11/16"X16			12	10	36.5	19	22
2BF-06	G3/8"X19	11/16"X16			13.5	10	40	22	22
2BF-06-08	G3/8"X19	13/16"X16			13.5	11	42	22	27
2BF-08-06	G1/2"X14	11/16"X16			16	10	44.5	27	22
2BF-08	G1/2"X14	13/16"X16			16	11	46.5	27	27
2BF-08-10	G1/2"X14	1"X14			16	13.5	50.5	27	30
2BF-10	G5/8"X14	1"X14			17.5	13.5	52	30	30
2BF-12-10	G3/4"X14	1"X14			18.5	13.5	54	32	30
2BF-12	G3/4"X14	1.3/16"X12			18.5	15	55.5	32	36
2BF-16-12	G1"X11	1.3/16"X12			20.5	15	59.5	41	36
2BF-16	G1"X11	1.7/16"X12			20.5	15	60.5	41	41
2BF-20	G1.1/4"X11	1.11/16"X1			20.5	15	63	50	50
2BF-20-16	G1.1/4"X11	1.7/16"X12			20.5	15	63.5	50	41
2BF-24	G1.1/2"X11	2"X12			23	14.8	68	50	60

2BJ

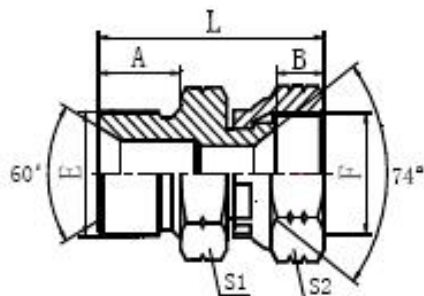

英管外螺纹 60°内锥/美制 JIC 内螺纹 74°内锥

BSP MALE 60° SEAT/JIC FEMALE 74° SEAT

代号 P/N	螺纹 Thread		O 形圈 O-Ring		尺寸 DIMENSIONS				
	E	F	E END	F END	A	B	L	S1	S2
2BJ-02-04	G1/8"X28	7/16"X20			10	9	24	14	15
2BJ-02-06	G1/8"X28	9/16"X18			10	10.5	24.5	14	19
2BJ-04	G1/4"X19	7/16"X20			12	9	26	19	15
2BJ-04-05	G1/4"X19	1/2"X20			12	9.5	26.5	19	17
2BJ-04-06	G1/4"X19	9/16"X18			12	10.5	27	19	19
2BJ-04-08	G1/4"X19	3/4"X16			12	11	29	19	24
2BJ-06	G3/8"X19	9/16"X18			13.5	10.5	30.5	22	19
2BJ-06-08	G3/8"X19	3/4"X16			13.5	11	32.5	22	24
2BJ-06-10	G3/8"X19	7/8"X14			13.5	13	33	22	27
2BJ-08	G1/2"X14	3/4"X16			16	11	37	27	24
2BJ-08-06	G1/2"X14	9/16"X18			16	10.5	35	27	19
2BJ-08-10	G1/2"X14	7/8"X14			16	13	37.5	27	27
2BJ-10	G5/8"X14	7/8"X14			17.5	14	41.5	30	27
2BJ-12	G3/4"X14	1.1/16"X12			18.5	15	42	32	32
2BJ-12-08	G3/4"X14	3/4"X16			18.5	11	40	32	24
2BJ-12-10	G3/4"X14	7/8"X14			18.5	13	41	32	27
2BJ-12-16	G3/4"X14	1.5/16"X12			18.5	16	42	32	41
2BJ-16	G1"X11	1.5/16"X12			20.5	16	46	41	41
2BJ-16-20	G1"X11	1.5/8"X12			20.5	17	50	41	50

2BJ-20	G1.1/4"X11	1.5/8"X12			20.5	17	49.5	50	50
2BJ-20-24	G1.1/4"X11	1.7/8"X12			20.5	20	50	50	55
2BJ-24	G1.1/2"X11	1.7/8"X12			23	20	52.5	55	55
2BJ-32	G2"X11	2.1/2"X12			25.5	24.5	57.5	70	75

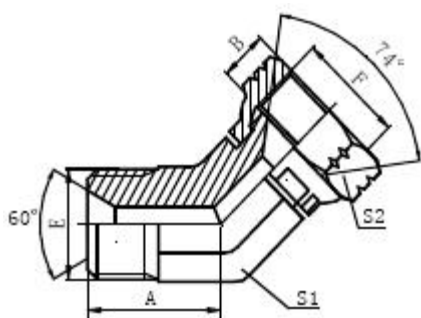

2BJ4

45°英管外螺纹 60°内锥/美制 JIC 内螺纹 74°内锥

45° BSP MALE 60° SEAT/JIC FEMALE 74°CONE

代号 P/N	螺纹 Thread		O 形圈 O-Ring		尺寸 DIMENSIONS				
	E	F	E END	F END	A	B	S1	S2	
2BJ4-04	G1/4"X19	7/16"X20			20.3	9	14	15	
2BJ4-06	G3/8"X19	9/16"X18			22	10.5	16	19	
2BJ4-08	G1/2"X14	3/4"X16			27	11	22	24	
2BJ4-10	G5/8"X14	7/8"X14			28.5	13	22	27	
2BJ4-12	G3/4"X14	1.1/16"X12			31	15	27	32	
2BJ4-16	G1"X11	1.5/16"X12			35	16	33	41	

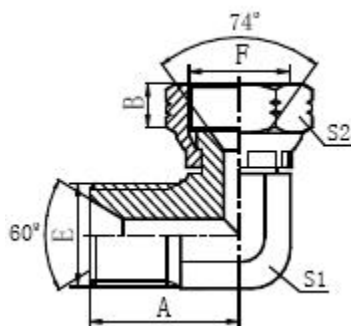

2BJ9

90°英管外螺纹 60°内锥/美制 JIC 内螺纹 74°内锥

90° BSP MALE 60° SEAT/JIC FEMALE 74° SEAT

代号 P/N	螺纹 Thread		O 形圈 O-Ring		尺寸 DIMENSIONS				
	E	F	E END	F END	A	B	S1	S2	
2BJ9-04	G 1/4"X19	7/16"X20			24.5	9	14	15	
2BJ9-06	G 3/8"X19	9/16"X18			27.5	10.5	16	19	
2BJ9-08	G 1/2"X14	3/4"X16			34.5	11	22	24	
2BJ9-10	G 5/8"X14	7/8"X14			35	13	22	27	
2BJ9-12	G 3/4"X14	1.1/16"X12			40	15	27	32	
2BJ9-16	G 1"X11	1.5/16"X12			46	16	33	41	

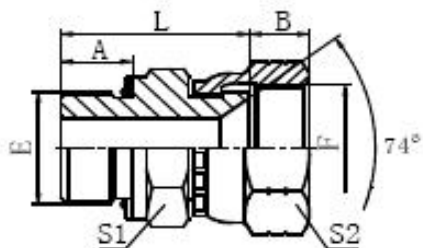

2GJ

英管外螺纹 O 形圈/JIC 内螺纹 74°锥面

BSP MALE O-RING/JIC FEMALE 74° CONE

代号 P/N	螺纹 Thread		O 形圈 O-Ring		尺寸 DIMENSIONS				
	E	F	E END	F END	A	B	L	S1	S2
2GJ-04	G1/4"X19	7/16"X20	10.77X2.62		10	9	24	19	15
2GJ-04-05	G1/4"X19	1/2"X20	10.77X2.62		10	9	24.	19	17
2GJ-04-06	G1/4"X19	9/16"X18	10.77X2.62		10	10.	24.	19	19
2GJ-04-08	G1/4"X19	3/4"X16	10.77X2.62		10	10.	26.	19	24
2GJ-06	G3/8"X19	9/16"X18	13.94X2.62		11.	10.	28	22	19
2GJ-06-08	G3/8"X19	3/4"X16	13.94X2.62		11.	10.	30	22	24
2GJ-08	G1/2"X14	3/4"X16	17.12X2.62		14	10.	34.	27	24
2GJ-08-06	G1/2"X14	9/16"X18	17.12X2.62		14	10.	32.	27	19
2GJ-08-10	G1/2"X14	7/8"X14	17.12X2.62		14	12	35	27	27
2GJ-12	G3/4"X14	1.1/16"X12	23.47X2.62		15.	15	39	32	32
2GJ-12-08	G3/4"X14	3/4"X16	23.47X2.62		15.	10.	37	32	24
2GJ-12-10	G3/4"X14	7/8"X14	23.47X2.62		15.	11	37.	32	27
2GJ-12-16	G3/4"X14	1.5/16"X12	23.47X2.62		15.	16	39	32	41
2GJ-16	G1"X11	1.5/16"X12	29.74X3.53		18	16	43.	41	41
2GJ-20	G1.1/4"X11	1.5/8"X12	37.69X3.53		20	17	49	50	50
2GJ-24	G1.1/2"X11	1.7/8"X12	44.04X3.53		21.	20	51	55	55

2GJ9-OG

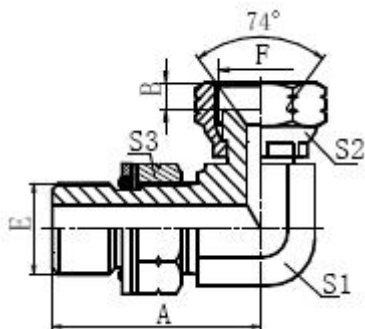

90°英管外螺纹 O 形圈/JIC 内螺纹 74°锥面

90° BSPP MALE O-RING/JIC FEMALE 74° CONE

代号 P/N	螺纹 Thread		O 形圈 O-Ring		尺寸 DIMENSIONS				
	E	F	E END	F END	A	B	S1	S2	S3
2GJ9-04OG	G1/4"X19	7/16"X20	10.77X2.62		31.3	9	14	15	19
2GJ9-04-05	G1/4"X19	1/2"X20	10.77X2.62		31.3	9	14	17	19
2GJ9-04-06	G1/4"X19	9/16"X18	10.77X2.62		31.3	10.5	14	19	19
2GJ9-04-08	G1/4"X19	3/4"X16	10.77X2.62		32.5	10.5	16	24	19
2GJ9-06OG	G3/8"X19	9/16"X18	13.94X2.62		35.8	10.5	16	19	22
2GJ9-06-08	G3/8"X19	3/4"X16	13.94X2.62		35.8	10.5	16	24	22
2GJ9-08OG	G1/2"X14	3/4"X16	17.12X2.62		43.2	10.5	22	24	27
2GJ9-08-06	G1/2"X14	9/16"X18	17.12X2.62		43.2	10.5	22	19	27
2GJ9-08-10	G1/2"X14	7/8"X14	17.12X2.62		43.2	12	22	27	27
2GJ9-12OG	G3/4"X14	1.1/16"X12	23.47X2.62		49.3	15	27	32	32
2GJ9-12-08	G3/4"X14	3/4"X16	23.47X2.62		49.3	10.5	27	24	32
2GJ9-12-10	G3/4"X14	7/8"X14	23.47X2.62		49.3	12	27	27	32
2GJ9-12-16	G3/4"X14	1.5/16"X12	23.47X2.62		52	16	30	41	32
2GJ9-16OG	G1"X11	1.5/16"X12	29.74X3.53		53	16	33	41	41
2GJ9-20OG	G1.1/4"X11	1.5/8"X12	37.69X3.53		58	17	41	50	50
2GJ9-24OG	G1.1/2"X11	1.7/8"X12	44.04X3.53		63	20	48	55	55

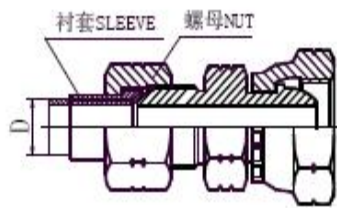
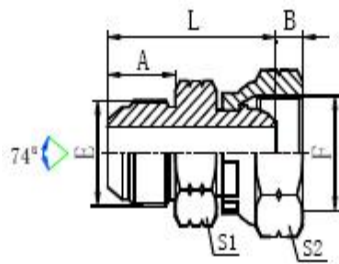

2JA

美制 JIC 外螺纹/英管内螺纹球面

JIC MALE / BSP FEMALE MULTISEAL

代号 P/N	螺纹 Thread		O形圈 O-Ring		尺寸 DIMENSIONS				
	E	F	E END	F END	A	B	L	S1	S2
2JA-20	1.5/8"X12	G1.1/4"X1			24.3	10	57	46	50
2JA-24	1.7/8"X12	G1.1/2"X1			27.5	11	63.5	50	55
2JA-32	2.1/2"X12	G2"X11			34	15	74	65	70

Note: Nut and sleeve should be ordered separately. The nut NB200 and sleeve NB500 is suitable for metric tube, the nut NB200 and sleeve NB300 is suitable for inch tube.

2JB

JIC外螺纹 74°外锥/英管内螺纹 60°外锥

JIC MALE 74° CONE/BSP FEMALE 60

° CONE

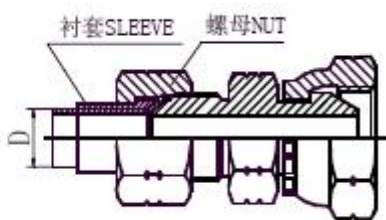
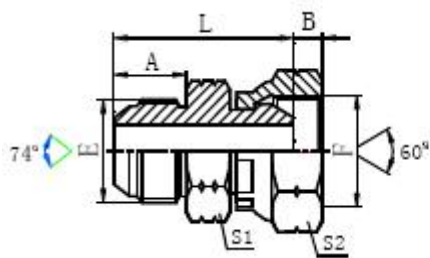

代号 P/N	螺纹 Thread		O形圈 O-Ring		尺寸 DIMENSIONS				
	E	F	E END	F END	A	B	L	S1	S2
2JB-04	7/16"X20	G1/4"X19			14	5.5	31	12	19
2JB-04-02	7/16"X20	G1/8"X28			14	5.5	29	14	14
2JB-04-06	7/16"X20	G3/8"X19			14	6.3	32.5	17	22
2JB-05-02	1/2"X20	G1/8"X28			14	5.5	29	14	14
2JB-05-04	1/2"X20	G1/4"X19			14	5.5	31	14	19
2JB-06	9/16"X18	G3/8"X19			14.1	6.3	32.5	17	22
2JB-06-04	9/16"X18	G1/4"X19			14.1	5.5	31	17	19
2JB-06-08	9/16"X18	G1/2"X14			14.1	7.5	34	19	27
2JB-08	3/4"X16	G1/2"X14			16.7	7.5	38.5	22	27
2JB-08-04	3/4"X16	G1/4"X19			16.7	5.5	35.5	22	19
2JB-08-06	3/4"X16	G3/8"X19			16.7	6.3	37	22	22
2JB-08-12	3/4"X16	G3/4"X14			16.7	10.9	42	27	32
2JB-10	7/8"X14	G5/8"X14			19.3	9.5	42	24	30
2JB-10-08	7/8"X14	G1/2"X14			19.3	7.5	41	24	27
2JB-12	1.1/16"X12	G3/4"X14			21.9	10.9	47	30	32
2JB-12-08	1.1/16"X12	G1/2"X14			21.9	7.5	46	30	27
2JB-12-16	1.1/16"X12	G1"X11			21.9	11.7	49.5	32	41
2JB-16	1.5/16"X12	G1"X11			23.1	11.7	51	36	41
2JB-20	1.5/8"X12	G1.1/4"X11			24.3	11	55.5	46	50

2JB-20-16	1.5/8"X12	G1"X11			24.3	11.7	53.5	46	41
2JB-24	1.7/8"X12	G1.1/2"X11			27.5	13	61.5	50	55
2JB-24-20	1.7/8"X12	G1.1/4"X11			27.5	11	61	50	50

Note: Nut and sleeve should be ordered separately. The nut NB200 and sleeve NB500 is suitable for metric tube, the nut NB200 and sleeve NB300 is suitable for inch tube.

2JB4

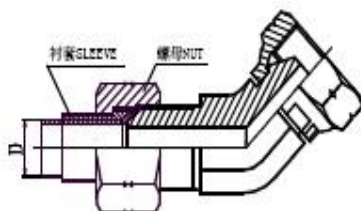
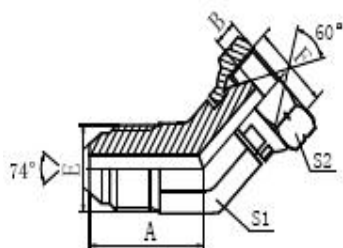

45° JIC 外螺纹 74°外锥/英管内螺纹 60°外锥

45° JIC MALE 74° CONE/BSP FEMALE

60° CONE

代号 P/N	螺纹 Thread		O形圈 O-Ring		尺寸 DIMENSIONS				
	E	F	E END	F END	A	B	S1	S2	
2JB4-04	7/16"X20	G1/4"X19			21.5	5.5	11	19	
2JB4-06	9/16"X18	G3/8"X19			22.8	6.3	14	22	
2JB4-08	3/4"X16	G1/2"X14			26.8	7.5	19	27	
2JB4-10	7/8"X14	G5/8"X14			31	9.5	22	30	
2JB4-12	1.1/16"X12	G3/4"X14			35.5	10.9	27	32	
2JB4-16	1.5/16"X12	G1"X11			38.5	11.7	33	41	

Note: Nut and sleeve should be ordered separately. The nut NB200 and sleeve NB500 is suitable for metric tube, the nut NB200 and sleeve NB300 is suitable for inch tube.

2JB9

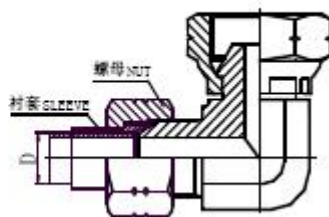
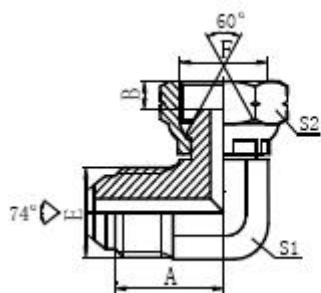

90° JIC 外螺纹 74°外锥/英管内螺纹 60°外锥

90° JIC MALE 74° CONE/BSP FEMALE 60°

CONE

代号 P/N	螺纹 Thread		O形圈 O-Ring		尺寸 DIMENSIONS				
	E	F	E END	F END	A	B	S1	S2	
2JB9-04	7/16"X20	G1/4"X19			24.5	5.5	11	19	
2JB9-06	9/16"X18	G3/8"X19			26.9	6.3	14	22	
2JB9-08	3/4"X16	G1/2"X14			32	7.5	19	27	
2JB9-10	7/8"X14	G5/8"X14			37.8	9.5	22	30	
2JB9-12	1.1/16"X12	G3/4"X14			44.2	10.9	27	32	
2JB9-16	1.5/16"X12	G1"X11			49	11.7	33	41	

Note: Nut and sleeve should be ordered separately. The nut NB200 and sleeve NB500 is suitable for metric tube, the nut NB200 and sleeve NB300 is suitable for inch tube.

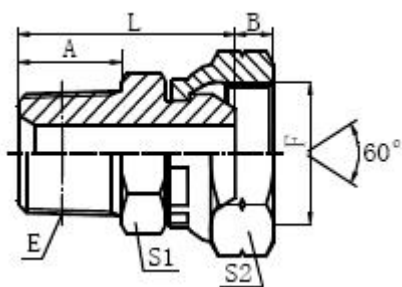

2NB

布锥管外螺纹/英管内螺纹 60°外锥

NPT MALE/BSP FEMALE 60° CONE

代号 P/N	螺纹 Thread		O形圈 O-Ring		尺寸 DIMENSIONS				
	E	F	E END	F END	A	B	L	S1	S2
2NB-02	Z1/8"X27	G1/8"X28			10.5	5.5	25.5	12	14
2NB-02-04	Z1/8"X27	G1/4"X19			10.5	5.5	27	14	19
2NB-04-02	Z1/4"X18	G1/8"X28			15	5.5	30	17	14
2NB-04	Z1/4"X18	G1/4"X19			15	5.5	31	17	19
2NB-04-06	Z1/4"X18	G3/8"X19			15	6.3	32.5	17	22
2NB-04-08	Z1/4"X18	G1/2"X14			15	7.5	35	19	27
2NB-06	Z3/8"X18	G3/8"X19			16	6.3	33.5	19	22
2NB-06-04	Z3/8"X18	G1/4"X19			16	5.5	33	19	19
2NB-06-08	Z3/8"X18	G1/2"X14			16	7.5	36	19	27
2NB-08	Z1/2"X14	G1/2"X14			19.5	7.5	41	22	27
2NB-08-04	Z1/2"X14	G1/4"X19			19.5	5.5	38.5	22	19
2NB-08-06	Z1/2"X14	G3/8"X19			19.5	6.3	39.5	22	24
2NB-08-12	Z1/2"X14	G3/4"X14			19.5	10.9	44.5	27	32
2NB-12	Z3/4"X14	G3/4"X14			19.5	10.9	44.5	30	32
2NB-12-06	Z3/4"X14	G3/8"X19			19.5	6.3	41.7	30	22
2NB-12-08	Z3/4"X14	G1/2"X14			19.5	7.5	43.5	30	27
2NB-12-16	Z3/4"X14	G1"X11			19.5	11.7	46.5	32	41
2NB-16-12	Z1"X11.5	G3/4"X14			21.5	10.9	51.5	36	32
2NB-16	Z1"X11.5	G1"X11			25.5	11.7	52.5	36	41
2NB-20	Z1.1/4"X11.5	G1.1/4"X11			26.5	11	59.5	46	50

2NB-24	Z1.1/2"X11.5	G1.1/2"X11			27.5	13	61.5	50	55
2NB-32	Z2"X11.5	G2"X11			27.5	16	66.5	65	70

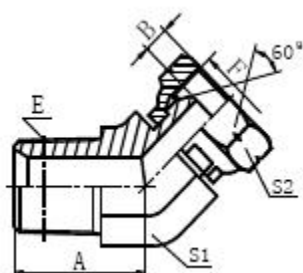

2NB4

45° 布锥管外螺纹/英管内螺纹 60°外锥

45° NPT MALE/BSP FEMALE 60° CONE

代号 P/N	螺纹 Thread		O形圈 O-Ring		尺寸 DIMENSIONS				
	E	F	E END	F END	A	B	S1	S2	
2NB4-02	Z1/8"X27	G1/8"X28			17	5.5	11	14	
2NB4-04	Z1/4"X18	G1/4"X19			21	5.5	14	19	
2NB4-04-0	Z1/4"X18	G3/8"X19			21	6.3	14	22	
2NB4-06	Z3/8"X18	G3/8"X19			24	6.3	19	22	
2NB4-06-0	Z3/8"X18	G1/4"X19			24	5.5	19	19	
2NB4-06-0	Z3/8"X18	G1/2"X14			24	7.5	19	27	
2NB4-08	Z1/2"X14	G1/2"X14			29.5	7.5	22	27	
2NB4-08-0	Z1/2"X14	G3/8"X19			29.5	6.3	22	22	
2NB4-08-1	Z1/2"X14	G3/4"X14			31	10.9	27	32	
2NB4-12	Z3/4"X14	G3/4"X14			35	10.9	27	32	
2NB4-12-0	Z3/4"X14	G1/2"X14			35	7.5	27	27	
2NB4-12-1	Z3/4"X14	G1"X11			35.5	11.7	30	41	
2NB4-16	Z1"X11.5	G1"X11			39	11.7	33	41	
2NB4-16-1	Z1"X11.5	G3/4"X14			39	10.9	33	32	
2NB4-20	Z1.1/4"X11.5	G1.1/4"X11			42.5	11	41	50	
2NB4-24	Z1.1/2"X11.5	G1.1/2"X11			45	13	48	55	
2NB4-32	Z2"X11	G2"X11			52.5	16	63	70	

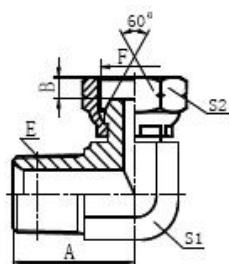

2NB9

90° 布锥管外螺纹/英管内螺纹 60°外锥

90° NPT MALE/BSP FEMALE 60° CONE

代号 P/N	螺纹 Thread		O形圈 O-Ring		尺寸 DIMENSIONS				
	E	F	E END	F END	A	B	S1	S2	
2NB9-02	Z1/8"X27	G1/8"X28			21	5.5	11	14	
2NB9-02-04	Z1/8"X27	G1/4"X19			21	5.5	11	19	
2NB9-04	Z1/4"X18	G1/4"X19			25.5	5.5	14	19	
2NB9-04-02	Z1/4"X18	G1/8"X28			25.5	5.5	14	14	
2NB9-04-06	Z1/4"X18	G3/8"X19			25.5	6.3	14	22	
2NB9-06	Z3/8"X18	G3/8"X19			31	6.3	19	22	
2NB9-06-04	Z3/8"X18	G1/4"X19			31	5.5	19	19	
2NB9-06-08	Z3/8"X18	G1/2"X14			31	7.5	19	27	
2NB9-08	Z1/2"X14	G1/2"X14			37.3	7.5	22	27	
2NB9-08-04	Z1/2"X14	G1/4"X19			36.7	5.5	22	19	
2NB9-08-06	Z1/2"X14	G3/8"X19			36.7	6.3	22	22	
2NB9-08-12	Z1/2"X14	G3/4"X14			37.5	10.9	24	32	
2NB9-12	Z3/4"X14	G3/4"X14			43.5	10.9	27	32	
2NB9-12-08	Z3/4"X14	G1/2"X14			44	7.5	27	27	
2NB9-12-16	Z3/4"X14	G1"X11			45	11.7	30	41	
2NB9-16	Z1"X11.5	G1"X11			50	11.7	33	41	
2NB9-16-08	Z1"X11.5	G1/2"X14			50	7.5	33	27	
2NB9-16-12	Z1"X11.5	G3/4"X14			50	10.9	33	32	
2NB9-20	Z1.1/4"X11.5	G1.1/4"X11			60	11	41	50	
2NB9-24	Z1.1/2"X11.5	G1.1/2"X11			59	13	48	55	
2NB9-32	Z2"X11.5	G2"X11			73.5	16	63	70	

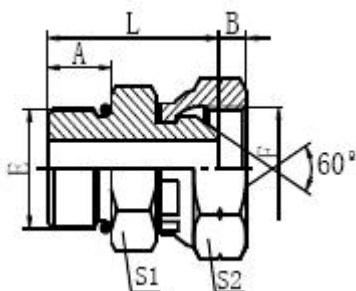

2OB

SAE 外螺纹带 O 形圈/英管内螺纹 60°外锥

SAE O-RING BOSS/BSP FEMALE 60° CONE

代号 P/N	螺纹 Thread		O 形圈 O-Ring		尺寸 DIMENSIONS				
	E	F	E END	F END	A	B	L	S1	S2
2OB-04	7/16"X20	G1/4"X19	8.92X1.83		9.1	5.5	26	14	19
2OB-04-06	7/16"X20	G3/8"X19	8.92X1.83		9.1	6.3	27	17	22
2OB-05-06	1/2"X20	G3/8"X19	10.52X1.83		9.1	6.3	27	17	22
2OB-06	9/16"X18	G3/8"X19	11.89X1.98		9.9	6.3	28	17	22
2OB-06-04	9/16"X18	G1/4"X19	11.89X1.98		9.9	5.5	27	17	19
2OB-06-08	9/16"X18	G1/2"X14	11.89X1.98		9.9	7.5	30	19	27
2OB-08	3/4"X16	G1/2"X14	16.36X2.21		11.1	7.5	33	22	27
2OB-08-06	3/4"X16	G3/8"X19	16.36X2.21		11.1	6.3	31	22	22
2OB-08-12	3/4"X16	G3/4"X14	16.36X2.21		11.1	10.9	36	27	32
2OB-10-06	7/8"X14	G3/8"X19	19.18X2.46		12.7	6.3	35	27	22
2OB-10-08	7/8"X14	G1/2"X14	19.18X2.46		12.7	7.5	36.5	27	27
2OB-10-12	7/8"X14	G3/4"X14	19.18X2.46		12.7	10.9	37.5	27	32
2OB-12-08	1.1/16"X12	G1/2"X14	23.47X2.95		15.1	7.5	40	32	27
2OB-12	1.1/16"X12	G3/4"X14	23.47X2.95		15.1	10.9	41	32	32
2OB-12-16	1.1/16"X12	G1"X11	23.47X2.95		15.1	11.7	42	32	41
2OB-16-12	1.5/16"X12	G3/4"X14	29.74X2.95		15.1	10.9	41	38	32
2OB-16	1.5/16"X12	G1"X11	29.74X2.95		15.1	11.7	42	38	41

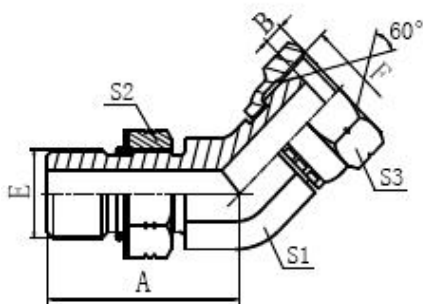

2OB4-OG

SAE 外螺纹带 O 形圈/英管内螺纹 60°外锥

SAE MALE WITH O-RING/BSP FEMALE 60°CONE

代号 P/N	螺纹 Thread		O 形圈 O-Ring		尺寸 DIMENSIONS				
	E	F	E END	F END	A	B	S1	S2	S3
2OB4-04OG	7/16"X20	G1/4"X19	8.92X1.83		24	5.5	11	17	19
2OB4-04-06	7/16"X20	G3/8"X19	8.92X1.83		23.5	6.3	14	17	22
2OB4-06-04	9/16"X18	G1/4"X19	11.89X1.98		27.5	5.5	14	19	19
2OB4-06OG	9/16"X18	G3/8"X19	11.89X1.98		27.5	6.3	14	19	22
2OB4-08OG	3/4"X16	G1/2"X14	16.36X2.21		31.5	7.5	19	24	27
2OB4-08-06	3/4"X16	G3/8"X19	16.36X2.21		31.5	6.3	19	24	22
2OB4-08-12	3/4"X16	G3/4"X14	16.36X2.21		34	10.9	27	24	32
2OB4-10-08	7/8"X14	G1/2"X14	19.18X2.46		38.5	7.5	22	27	27
2OB4-12OG	1.1/16"X12	G3/4"X14	23.47X2.95		43.5	10.9	27	32	32

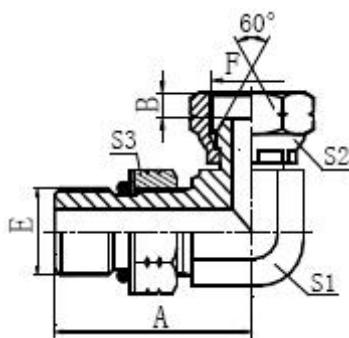

2OB9-OG

SAE 外螺纹带 O 形圈/英管内螺纹 60°外锥

SAE O-RING BOSS/BSP FEMALE 60° CONE

代号 P/N	螺纹 Thread		O 形圈 O-Ring		尺寸 DIMENSIONS				
	E	F	E END	F END	A	B	S1	S2	S3
2OB9-04OG	7/16"X20	G1/4"X19	8.92X1.83		27.2	5.5	11	19	17
2OB9-06OG	9/16"X18	G3/8"X19	11.89X1.98		33.3	6.3	16	19	22
2OB9-06-04	9/16"X18	G1/4"X19	11.89X1.98		31.8	5.5	14	19	19
2OB9-06-08	9/16"X18	G1/2"X14	11.89X1.98		33.5	7.5	19	24	27
2OB9-08-06	3/4"X16	G3/8"X19	16.36X2.21		36.8	6.3	19	24	22
2OB9-08OG	3/4"X16	G1/2"X14	16.36X2.21		36.8	7.5	19	24	27
2OB9-08-10	3/4"X16	G5/8"X14	16.36X2.21		39.5	9.5	22	30	27
2OB9-08-12	3/4"X16	G3/4"X14	16.36X2.21		40.5	10.9	24	32	32
2OB9-10-08	7/8"X14	G1/2"X14	19.18X2.46		44	7.5	22	27	27
2OB9-12OG	1.1/16"X12	G3/4"X14	23.47X2.95		51	10.9	27	32	32
2OB9-12-08	1.1/16"X12	G1/2"X14	23.47X2.95		51	7.5	27	32	27
2OB9-16OG	1.5/16"X12	G1"X11	29.74X2.95		54.5	11.7	33	41	41
2OB9-20OG	1.5/8"X12	G1.1/4"X11	37.46X3.00		59.5	11	41	50	50
2OB9-24OG	1.7/8"X12	G1.1/2"X11	43.69X3.00		63	13	48	55	55

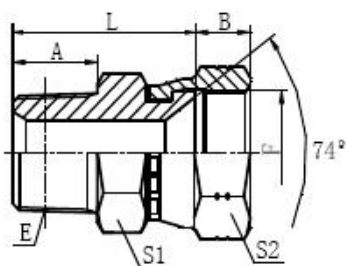

2TJ-SP

英锥管外螺纹/美制 JIC 内螺纹 74°内锥

BSPT MALE/JIC FEMALE 74° SEAT

代号 P/N	螺纹 Thread		O 形圈 O-Ring		尺寸 DIMENSIONS				
	E	F	E END	F END	A	B	L	S1	S2
2TJ-02-04SP	R1/8"X28	7/16"X20			10	9	24	12	17
2TJ-04SP	R1/4"X19	7/16"X20			14	9	28	14	17
2TJ-04-05SP	R1/4"X19	1/2"X20			14	9	28.5	14	17
2TJ-04-06SP	R1/4"X19	9/16"X18			14	10.5	28.5	14	19
2TJ-06-05SP	R3/8"X19	1/2"X20			15	9	29.5	19	17
2TJ-06SP	R3/8"X19	9/16"X18			15	10.5	29.5	17	19
2TJ-06-08SP	R3/8"X19	3/4"X16			15	10.5	31.5	19	24
2TJ-08SP	R1/2"X14	3/4"X16			19	10.5	37.5	24	24
2TJ-08-10SP	R1/2"X14	7/8"X14			19	12	38	24	27
2TJ-08-12SP	R1/2"X14	1.1/16"X12			20	15	41.5	27	32
2TJ-12SP	R3/4"X14	1.1/16"X12			19	15	41.5	30	32
2TJ-12-16SP	R3/4"X14	1.5/16"X12			20	16	43.5	32	41
2TJ-16SP	R1"X11	1.5/16"X12			24	16	47.5	36	41
2TJ-20SP	R1.1/4"X11	1.5/8"X12			25	17	52	46	50
2TJ-24SP	R1.1/2"X11	1.7/8"X12			26.5	20	56	50	55

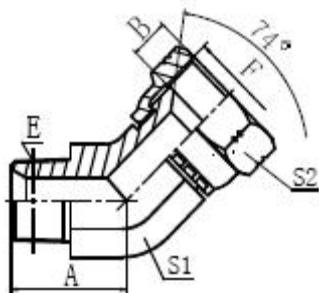

2TJ4-SP

45°英锥管外螺纹/美制 JIC 内螺纹 74°内锥

45° BSPT MALE/JIC FEMALE 74° SEAT

代号 P/N	螺纹 Thread		O 形圈 O-Ring		尺寸 DIMENSIONS				
	E	F	E END	F END	A	B	S1	S2	
2TJ4-04SP	R1/4"x19	7/16"x20			21	9	14	15	
2TJ4-04-06	R1/4"x19	9/16"x18			21	10.5	14	19	
2TJ4-06SP	R3/8"x19	9/16"x18			23	10.5	16	19	
2TJ4-08SP	R1/2"x14	3/4"x16			29.5	11	22	24	
2TJ4-08-10	R1/2"x14	7/8"x14			29.5	13	22	27	
2TJ4-12SP	R3/4"x14	1.1/16"x12			30.5	15	27	32	

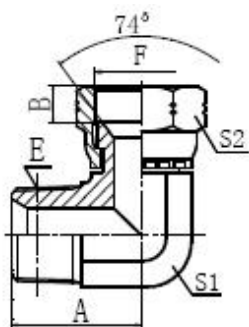

2TJ9-SP

90°英锥管外螺纹/美制 JIC 内螺纹 74°内锥

90° BSPT MALE/JIC FEMALE 74° SEAT

代号 P/N	螺纹 Thread		O 形圈 O-Ring		尺寸 DIMENSIONS				
	E	F	E END	F END	A	B	S1	S2	
2TJ9-04SP	R1/4"X19	7/16"X20			26	9	14	15	
2TJ9-04-06S	R1/4"X19	9/16"X18			25.5	10.5	14	19	
2TJ9-06SP	R3/8"X19	9/16"X18			29	10.5	16	19	
2TJ9-08SP	R1/2"X14	3/4"X16			37	11	22	24	
2TJ9-08-10S	R1/2"X14	7/8"X14			37	13	22	27	
2TJ9-12SP	R3/4"X14	1.1/16"X12			43.5	15	27	32	
2TJ9-12-16S	R3/4"X14	1.5/16"X12			46.5	16	33	41	
2TJ9-16SP	R1"X11	1.5/16"X12			50	16	33	41	

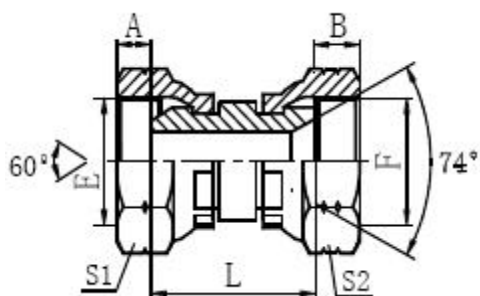

3BJ

英管内螺纹 60°外锥/美制 JIC 内螺纹 74°内锥

BSP FEMALE 60° CONE/JIC FEMALE 74° SEAT

代号 P/N	螺纹 Thread		O形圈 O-Ring		尺寸 DIMENSIONS				
	E	F	E END	F END	A	B	L	S1	S2
3BJ-04	G1/4"X19	7/16"X20			5.5	9	22	19	15
3BJ-04-05	G1/4"X19	1/2"X20			5.5	9.5	22.5	19	17
3BJ-04-06	G1/4"X19	9/16"X18			5.5	10.5	22.5	19	19
3BJ-06	G3/8"X19	9/16"X18			6.3	10.5	25	22	19
3BJ-06-04	G3/8"X19	7/16"X20			6.3	9	23.5	22	15
3BJ-06-08	G3/8"X19	3/4"X16			6.3	11	26.5	22	24
3BJ-06-10	G3/8"X19	7/8"X14			6.3	14	28	22	27
3BJ-08	G1/2"X14	3/4"X16			7.5	11	29	27	24
3BJ-08-06	G1/2"X14	9/16"X18			7.5	10.5	26	27	19
3BJ-08-10	G1/2"X14	7/8"X14			7.5	13	30	27	27
3BJ-08-12	G1/2"X14	1.1/16"X12			7.5	15	31	27	32
3BJ-10	G5/8"X14	7/8"X14			9.5	13	28.5	30	27
3BJ-12	G3/4"X14	1.1/16"X12			10.9	15	32	32	32
3BJ-12-08	G3/4"X14	3/4"X16			10.9	11	30	32	24
3BJ-16	G1"X11	1.5/16"X12			11.7	16	33	41	41

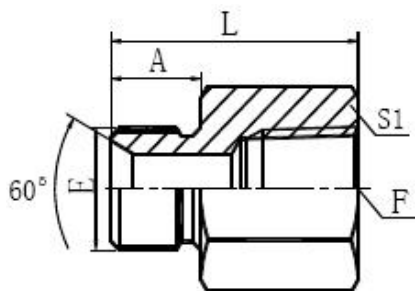

5BN

英管外螺纹 60°内锥/美制布锥管内螺纹

BSP MALE 60° SEAT/NPT FEMALE

代号 P/N	螺纹 Thread		O形圈 O-Ring		尺寸 DIMENSIONS				
	E	F	E END	F END	A	L	S1		
5BN-02	G1/8"X28	Z1/8"X27			10	25	17		
5BN-04	G1/4"X19	Z1/4"X18			12	31	19		
5BN-04-02	G1/4"X19	Z1/8"X27			12	27	19		
5BN-04-06	G1/4"X19	Z3/8"X18			12	33	22		
5BN-06	G3/8"X19	Z3/8"X18			13.5	33	22		
5BN-06-04	G3/8"X19	Z1/4"X18			13.5	32	22		
5BN-08	G1/2"X14	Z1/2"X14			16	44	30		
5BN-08-04	G1/2"X14	Z1/4"X18			16	23	27		
5BN-08-06	G1/2"X14	Z3/8"X18			16	34	27		
5BN-08-12	G1/2"X14	Z3/4"X14			16	43	36		
5BN-12	G3/4"X14	Z3/4"X14			18.5	45	36		
5BN-12-04	G3/4"X14	Z1/4"X18			18.5	26.5	32		
5BN-12-06	G3/4"X14	Z3/8"X18			18.5	26.5	32		
5BN-16	G1"X11	Z1"X11.5			20.5	54	41		
5BN-16-04	G1"X11	Z1/4"X18			20.5	32	41		
5BN-16-06	G1"X11	Z3/8"X18			20.5	32	41		
5BN-16-08	G1"X11	Z1/2"X14			20.5	32	41		
5BN-16-12	G1"X11	Z3/4"X14			20.5	44	41		
5BN-16-20	G1"X11	Z1.1/4"X11.			20.5	58	50		
5BN-20	G1.1/4"X11	Z1.1/4"X11.			20.5	58	50		

5BN-20-16	G1.1/4"X11	Z1"X11.5			20.5	48	50		
5BN-24	G1.1/2"X11	Z1.1/2"X11.			23	58	60		
5BN-24-16	G1.1/2"X11	Z1"X11.5			23	43	55		
5BN-24-20	G1.1/2"X11	Z1.1/4"X11.			23	56	55		
5BN-32	G2"X11	Z2"X11.5			25.5	62	70		

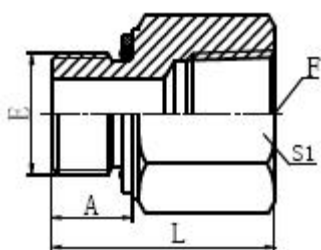

5GN

英管外螺纹 O 形圈/美制布锥管内螺纹

BSP MALE O-RING/NPT FEMALE

代号 P/N	螺纹 Thread		O 形圈 O-Ring		尺寸 DIMENSIONS				
	E	F	E END	F END	A	L	S1		
5GN-02	G1/8"X28	Z1/8"X27	7.65X1.78		9.5	25.5	17		
5GN-02-04	G1/8"X28	Z1/4"X18	7.65X1.78		9.5	31	19		
5GN-04-02	G1/4"X19	Z1/8"X27	10.77X2.62		10	26	19		
5GN-04	G1/4"X19	Z1/4"X18	10.77X2.62		10	31.5	19		
5GN-06	G3/9"X19	Z3/8"X18	13.94X2.62		11.5	35	22		
5GN-08	G1/2"X14	Z1/2"X14	17.12X2.62		14	43	30		
5GN-12	G3/4"X14	Z3/4"X14	23.47X2.62		15.5	44.5	36		
5GN-16	G1"X11	Z1"X11.5	29.74X3.53		18	54.5	41		
5GN-20	G1.1/4"X11	Z1.1/4"X11.	37.69X3.53		20	57	50		
5GN-24	G1.1/2"X11	Z1.1/2"X11.	44.04X3.53		21.5	57	60		

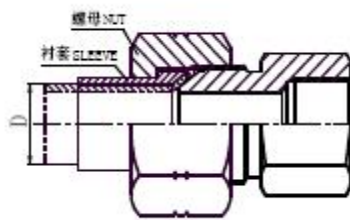
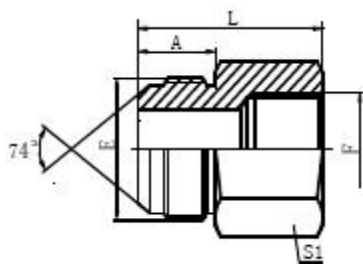

5JB

JIC 外螺纹 74°外锥/英管内螺纹

JIC MALE 74° CONE/BSP FEMALE

代号 P/N	螺纹 Thread		O 形圈 O-Ring		尺寸 DIMENSIONS				
	E	F	E END	F END	A	L	S1		
5JB-04	7/16"X20	G1/4"X19			14	35	19		
5JB-04-02	7/16"X20	G1/8"X28			14	30	14		
5JB-06	9/16"X18	G3/8"X19			14.1	36.8	22		
5JB-08	3/4"X16	G1/2"X14			16.7	45.2	30		
5JB-10-08	7/8"X14	G1/2"X14			19.3	47.5	30		
5JB-12	1.1/16"X12	G3/4"X14			21.9	51.8	36		
5JB-16	1.5/16"X12	G1"X11			23.1	59.2	46		
5JB-20	1.5/8"X12	G1.1/4"X1			24.3	58.7	50		
5JB-24	1.7/8"X12	G1.1/2"X1			27.5	62	60		

Note: Nut and sleeve should be ordered separately. The nut NB200 and sleeve NB500 is suitable for metric tube, the nut NB200 and sleeve NB300 is suitable for inch tube.

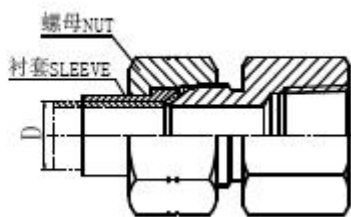
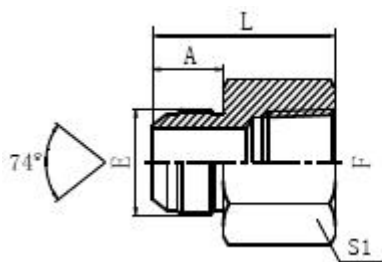

5JT

JIC 外螺纹 74°外锥/英锥管内螺纹

JIC MALE 74 ° CONE/BSPT

FEMALE

代号 P/N	螺纹 Thread		O形圈 O-Ring		尺寸 DIMENSIONS				
	E	F	E END	F END	A	L	S1		
5JT-04	7/16"X20	Rc1/4"X19			14	35.5	19		
5JT-04-02	7/16"X20	Rc1/8"X28			14	30	14		
5JT-05-04	1/2"X20	Rc1/4"X19			14	35.5	19		
5JT-06	9/16"X18	RC3/8"X19			14	36.5	22		
5JT-06-04	9/16"X18	Rc1/4"X19			14	35.5	19		
5JT-06-08	9/16"X18	Rc1/2"X14			14	42.5	27		
5JT-08	3/4"X16	Rc1/2"X14			16.7	45.5	27		
5JT-08-06	3/4"X16	RC3/8"X19			16.7	39.5	22		
5JT-10-06	7/8"X14	Rc3/8"X19			19.3	42	24		
5JT-10-08	7/8"X14	Rc1/2"X14			19.3	48	27		
5JT-12	1.1/16"X12	Rc3/4"X14			22	52.5	36		
5JT-12-08	1.1/16"X12	Rc1/2"X14			22	50.5	30		
5JT-16	1.5/16"X12	Rc1"X11			23	59.5	41		
5JT-16-12	1.5/16"X12	Rc3/4"X14			23.1	53.5	36		

Note: Nut and sleeve should be ordered separately. The nut NB200 and sleeve NB500 is suitable for metric tube, the nut NB200 and sleeve NB300 is suitable for inch tube.

5JT9

90° JIC 外螺纹 74°外锥/英锥管内螺纹

90°JIC MALE 74°CONE/BSPT

FEMALE

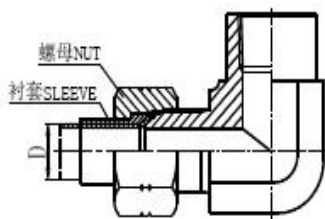
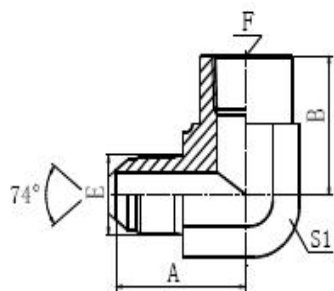

代号 P/N	螺纹 Thread		O形圈 O-Ring		尺寸 DIMENSIONS				
	E	F	E END	F END	A	B	S1		
5JT9-04-02	7/16"x20	Rc1/8"X28			27.5	20	16		
5JT9-04	7/16"x20	Rc1/4"X19			30	25	19		
5JT9-05-04	1/2"X20	Rc1/4"X19			30	25	19		
5JT9-06	9/16"X18	Rc3/8"X19			33.5	27	24		
5JT9-06-04	9/16"X18	Rc1/4"X19			30.5	25	19		
5JT9-08	3/4"X16	Rc1/2"X14			39.5	31.5	30		
5JT9-08-06	3/4"X16	Rc3/8"X19			36	27	24		
5JT9-10-08	7/8"X14	Rc1/2"X14			42.5	31.5	30		
5JT9-12	1.1/16"X12	Rc3/4"X14			48	37	33		
5JT9-12-08	1.1/16"X12	Rc1/2"X14			46.2	31.5	30		
5JT9-16	1.5/16"X12	Rc1"X11			54	43	41		
5JT9-20	1.5/8"X12	Rc1.1/4"X1			62	46	50		
5JT9-24	1.7/8"X12	Rc1.1/2"X1			74.5	55	63		

Note: Nut and sleeve should be ordered separately. The nut NB200 and sleeve NB500 is suitable for metric tube, the nut NB200 and sleeve NB300 is suitable for inch tube.

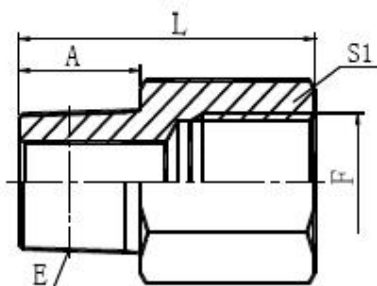

5NB

布锥管外螺纹/英管内螺纹

NPT MALE/BSP FEMALE

代号 P/N	螺纹 Thread		O形圈 O-Ring		尺寸 DIMENSIONS				
	E	F	E END	F END	A	L	S1		
5NB-02	Z1/8"X27	G1/8"X28			10.5	28	14		
5NB-02-04	Z1/8"X27	G1/4"X19			10.5	32	19		
5NB-04	Z1/4"X18	G1/4"X19			15	35	19		
5NB-04-02	Z1/4"X18	G1/8"X28			15	32	17		
5NB-06	Z3/8"X18	G3/8"X19			15	38	22		
5NB-06-04	Z3/8"X18	G1/4"X19			15	32	19		
5NB-08	Z1/2"X14	G1/2"X14			19.5	47.5	27		
5NB-08-04	Z1/2"X14	G1/4"X19			19.5	28	22		
5NB-08-06	Z1/2"X14	G3/8"X19			19.5	40	22		
5NB-12	Z3/4"X14	G3/4"X14			19.5	48.5	36		
5NB-12-04	Z3/4"X14	G1/4"X19			19.5	30	30		
5NB-12-06	Z3/4"X14	G3/8"X19			19.5	32	30		
5NB-12-08	Z3/4"X14	G1/2"X14			19.5	32	30		
5NB-16	Z1"X11.5	G1"X11			25.5	60	41		
5NB-16-04	Z1"X11.5	G1/4"X19			25.5	37	36		
5NB-16-06	Z1"X11.5	G3/8"X19			25.5	37	36		
5NB-16-08	Z1"X11.5	G1/2"X14			25.5	37	36		
5NB-16-12	Z1"X11.5	G3/4"X14			25.5	37	36		
5NB-20	Z1.1/4"X11.	G1.1/4"X1			26.5	61	50		

5NB-20-16	Z1.1/4"X11.	G1"X11			26.5	42	46		
5NB-24	Z1.1/2"X11.	G1.1/2"X1			27.5	64	55		
5NB-24-20	Z1.1/2"X11.	G1.1/4"X1			27.5	58	50		
5NB-32	Z2"X11.5	G2"X11			27.5	68	70		
5NB-32-16	Z2"X11.5	G1"X11			27.5	46	65		
5NB-32-20	Z2"X11.5	G1.1/4"X1			27.5	46	65		
5NB-32-24	Z2"X11.5	G1.1/2"X1			27.5	46	65		

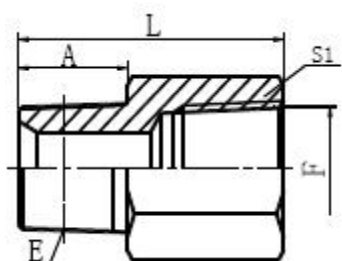

5NT

美制布锥管外螺纹/英锥管内螺纹

NPT MALE/BSPT FEMALE

代号 P/N	螺纹 Thread		O形圈 O-Ring		尺寸 DIMENSIONS				
	E	F	E END	F END	A	L	S1		
5NT-04	Z1/4"X18	Rc1/4"X19			15	35	19		
5NT-06	Z3/8"X18	Rc3/8"X19			16	37.5	24		
5NT-08	Z1/2"X14	Rc1/2"X14			19.5	47.5	30		
5NT-12	Z3/4"X14	Rc3/4"X14			19.5	49	36		
5NT-16	Z1"X11.5	Rc1"X11			25.5	60	41		
5NT-20	Z1.1/4"X11.	Rc1.1/4"X1			26.5	64.5	50		
5NT-24	Z1.1/2"X11.	Rc1.1/2"X1			27.5	65.5	55		
5NT-32	Z2"X11.5	Rc2"X11			27.5	68.5	70		

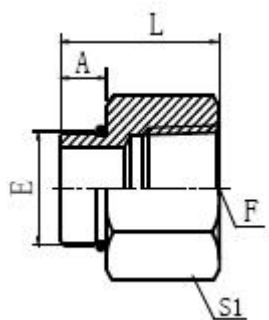

5OT

SAE 外螺纹带 O 形圈/英锥管内螺纹

SAE O-RING BOSS/BSPT FEMALE

代号 P/N	螺纹 Thread		O 形圈 O-Ring		尺寸 DIMENSIONS				
	E	F	E END	F END	A	L	S1		
5OT-04	7/16"X20	Rc1/4"X19	8.92X1.83		9.1	30.5	19		
5OT-04-02	7/16"X20	Rc1/8"X28	8.92X1.83		9.1	26	17		
5OT-06	9/16"X18	Rc3/8"X19	11.89X1.98		9.9	32.5	22		
5OT-06-04	9/16"X18	Rc1/4"X19	11.89X1.98		9.9	31.5	19		
5OT-08	3/4"X16	Rc1/2"X14	16.36X2.21		11.1	40	30		
5OT-08-02	3/4"X16	Rc1/8"X28	16.36X2.21		11.1	22	22		
5OT-08-04	3/4"X16	Rc1/4"X19	16.36X2.21		11.1	32.5	22		
5OT-08-06	3/4"X16	Rc3/8"X19	16.36X2.21		11.1	34	22		
5OT-10-06	7/8"X14	Rc3/8"X19	19.18X2.46		12.7	35.5	27		
5OT-10-08	7/8"X14	Rc1/2"X14	19.18X2.46		12.7	41.5	30		
5OT-12-06	1.1/16"X12	Rc3/8"X19	23.47X2.95		15.1	30.5	32		
5OT-12-08	1.1/16"X12	Rc1/2"X14	23.47X2.95		15.1	42	32		
5OT-16	1.5/16"X12	Rc1"X11	29.74X2.95		15.1	51.5	41		
5OT-16-08	1.5/16"X12	Rc1/2"X14	29.74X2.95		15.1	42	38		
5OT-16-12	1.5/16"X12	Rc3/4"X14	29.74X2.95		15.1	43	38		

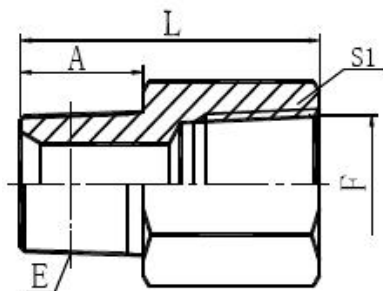

5TN-SP

英锥管外螺纹/美制布锥管内螺纹

BSPT MALE/NPT FEMALE

代号 P/N	螺纹 Thread		O 形圈 O-Ring		尺寸 DIMENSIONS				
	E	F	E END	F END	A	L	S1		
5TN-02SP	R1/8"X28	Z1/8"X27			10	26	17		
5TN-04-02S	R1/4"X19	Z1/8"X27			14.5	22	17		
5TN-04SP	R1/4"X19	Z1/4"X18			14.5	34.5	19		
5TN-06-02S	R3/8"X19	Z1/8"X27			15	23	19		
5TN-06-04S	R3/8"X19	Z1/4"X18			15	23	19		
5TN-06SP	R3/8"X19	Z3/8"X18			15	36.5	24		
5TN-08-04S	R1/2"X14	Z1/4"X18			20	29	24		
5TN-08-06S	R1/2"X14	Z3/8"X18			20	28.5	24		
5TN-08SP	R1/2"X14	Z1/2"X14			20	47	30		
5TN-12-06S	R3/4"X14	Z3/8"X18			20	30.5	30		
5TN-12-08S	R3/4"X14	Z1/2"X14			20	30.5	32		
5TN-12SP	R3/4"X14	Z3/4"X14			20	49	36		
5TN-16-04S	R1"X11	Z1/4"X18			25.5	35.5	36		
5TN-16-06S	R1"X11	Z3/8"X18			25.5	35.5	36		
5TN-16-08S	R1"X11	Z1/2"X14			25.5	35.5	36		
5TN-16-12S	R1"X11	Z3/4"X14			25.5	36.5	36		
5TN-16SP	R1"X11	Z1"X11.5			25.5	60	41		
5TN-20-08S	R1.1/4"X11	Z1/2"X14			26.5	38.5	46		
5TN-20-12S	R1.1/4"X11	Z3/4"X14			26.5	38.5	46		
5TN-20-16S	R1.1/4"X11	Z1"X11.5			26.5	41	46		

5TN-20SP	R1.1/4"X11	Z1.1/4"X11.			26.5	58.5	50		
5TN-24-08S	R1.1/2"X11	Z1/2"X14			26.5	41	50		
5TN-24-12S	R1.1/2"X11	Z3/4"X14			26.5	41	50		
5TN-24-16S	R1.1/2"X11	Z1"X11.5			26.5	41.5	50		
5TN-24-20S	R1.1/2"X11	Z1.1/4"X11.			26.5	41.5	50		
5TN-32-12S	R2"X11	Z3/4"X14			30	46	65		
5TN-32-16S	R2"X11	Z1"X11.5			30	47	65		
5TN-32-20S	R2"X11	Z1.1/4"X11.			30	47	65		
5TN-32-24S	R2"X11	Z1.1/2"X11.			30	47	65		
5TN-32SP	R2"X11	Z2"X11.5			30	64	70		

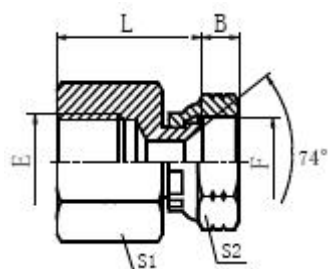

7BJ-S

英管内螺纹/JIC 内螺纹 74°内锥

BSP FEMALE/JIC FEMALE 74°SEAT

代号 P/N	螺纹 Thread		O 形圈 O-Ring		尺寸 DIMENSIONS				
	E	F	E END	F END	B	L	S1	S2	
7BJ-04-05S	G1/4"X19	1/2"X20			9.5	29.5	19	17	
7BJ-04S	G1/4"X19	7/16"X20			9	29	19	17	
7BJ-06S	G3/8"X19	9/16"X18			10.5	32.5	22	19	
7BJ-08-10S	G1/2"X14	7/8"X14			13	40	27	27	
7BJ-08S	G1/2"X14	3/4"X16			11	39.5	27	24	
7BJ-12S	G3/4"X14	1.1/16"X12			15	42	36	32	
7BJ-16S	G1"X11	1.5/16"X12			16	47.5	41	41	
7BJ-20S	G1.1/4"X11	1.5/8"X12			17	51	50	50	
7BJ-24S	G1.1/2"X11	1.7/8"X12			20	53	55	55	

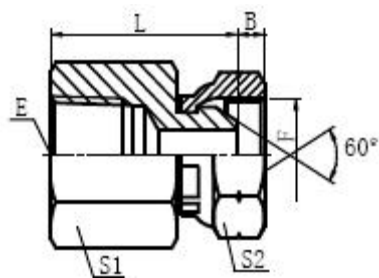

7NB-S

NPT 内螺纹/英制内螺纹 60°外锥

NPT FEMALE/BSP FEMALE 60° CONE

代号 P/N	螺纹 Thread		O形圈 O-Ring		尺寸 DIMENSIONS				
	E	F	E	F END	B	L	S1	S2	
7NB-02S	Z1/8"X27	G1/8"X28			5.5	25	17	14	
7NB-04S	Z1/4"X18	G1/4"X19			5.5	31.5	19	19	
7NB-06S	Z3/8"X18	G3/8"X19			6.3	34	24	22	
7NB-08S	Z1/2"X14	G1/2"X14			7.5	42	30	27	
7NB-12S	Z3/4"X14	G3/4"X14			10.9	44	36	32	
7NB-16S	Z1"X11.5	G1"X11			11.7	51.5	41	41	
7NB-20S	Z1.1/4"X11.5	G1.1/4"X11			11	55	50	50	
7NB-24S	Z1.1/2"X11.5	G1.1/2"X11			13	54	60	55	
7NB-32S	Z2"X11.5	G2"X11			16	57	70	70	

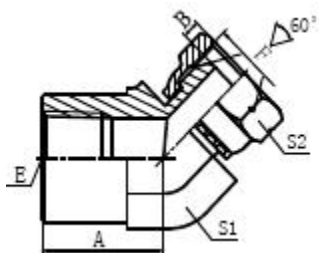

7NB4-S

45°布锥管内螺纹/英制内螺纹 60°外锥

45° NPT FEMALE/BSP FEMALE 60° CONE

代号 P/N	螺纹 Thread		O形圈 O-Ring		尺寸 DIMENSIONS				
	E	F	E	F END	A	B	S1	S2	
7NB4-02S	Z1/8"X27	G1/8"X28			17	5.5	16	14	
7NB4-04S	Z1/4"X18	G1/4"X19			20	5.5	19	19	
7NB4-06S	Z3/8"X18	G3/8"X19			19	6.3	24	22	
7NB4-08S	Z1/2"X14	G1/2"X14			28	7.5	30	27	
7NB4-12S	Z3/4"X14	G3/4"X14			30	10.9	33	32	
7NB4-16S	Z1"X11.5	G1"X11			37.5	11.7	41	41	
7NB4-20S	Z1.1/4"X11.5	G1.1/4"X11			38.5	11	48	50	
7NB4-24S	Z1.1/2"X11.5	G1.1/2"X11			41	13	63	55	

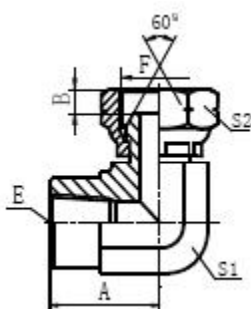

7NB9-S

90° 布锥管内螺纹/英管内螺纹 60°外锥

90° NPT FEMALE/BSP FEMALE 60° CONE

代号 P/N	螺纹 Thread		O形圈 O-Ring		尺寸 DIMENSIONS				
	E	F	E END	F END	A	B	S1	S2	
7NB9-02S	Z1/8"X27	G1/8"X28			17.8	5.5	16	14	
7NB9-04-0	Z1/4"X18	G1/8"X28			22.5	5.5	19	14	
7NB9-04S	Z1/4"X18	G1/4"X19			22.5	5.5	19	19	
7NB9-04-0	Z1/4"X18	G3/8"X19			22.5	6.3	19	22	
7NB9-06S	Z3/8"X18	G3/8"X19			27	6.3	24	22	
7NB9-06-0	Z3/8"X18	G1/4"X19			27	5.5	24	19	
7NB9-06-0	Z3/8"X18	G1/2"X14			27	7.5	24	27	
7NB9-08-0	Z1/2"X14	G1/4"X19			31.2	5.5	30	19	
7NB9-08-0	Z1/2"X14	G3/8"X19			31.2	6.3	30	22	
7NB9-08S	Z1/2"X14	G1/2"X14			31.2	7.5	30	27	
7NB9-12-0	Z3/4"X14	G3/8"X19			34.5	6.3	33	22	
7NB9-12-0	Z3/4"X14	G1/2"X14			34.5	7.5	33	27	
7NB9-12S	Z3/4"X14	G3/4"X14			34.5	10.9	33	32	
7NB9-12-1	Z3/4"X14	G1"X11			34.5	11.7	33	41	
7NB9-16S	Z1"X11.5	G1"X11			43	11.7	41	41	
7NB9-20S	Z1.1/4"X11.5	G1.1/4"X11			43.2	11	50	50	
7NB9-24S	Z1.1/2"X11.5	G1.1/2"X11			52.8	13	63	55	

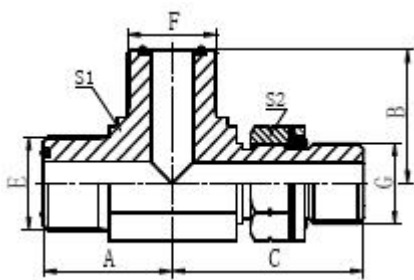

AFFG-OG

ORFS 外螺纹/ORFS 外螺纹/英管外螺纹 O 形圈

ORFS MALE/ORFS MALE/BSP MALE O-RING

代号 P/N	螺纹 Thread			尺寸 DIMENSIONS					
	E	F	G	A	B	C	S1	S2	
AFFG-04OG	9/16"X18	9/16"X18	G1/4"X19	23	23	31.3	14	19	
AFFG-06-06-04OG	11/16"X16	11/16"X16	G1/4"X19	27	27	33.5	19	19	
AFFG-06OG	11/16"X16	11/16"X16	G3/8"X19	27.5	27.5	36.8	19	22	
AFFG-08-08-06OG	13/16"X16	13/16"X16	G3/8"X19	31	31	39.5	22	22	
AFFG-08OG	13/16"X16	13/16"X16	G1/2"X14	31	31	43.2	22	27	
AFFG-10-10-12OG	1"X14	1"X14	G3/4"X14	36.5	36.5	49.3	27	32	
AFFG-12OG	1.3/16"X12	1.3/16"X12	G3/4"X14	42	42	53	33	32	
AFFG-16OG	1.7/16"X12	1.7/16"X12	G1"X11	48	48	58	41	41	

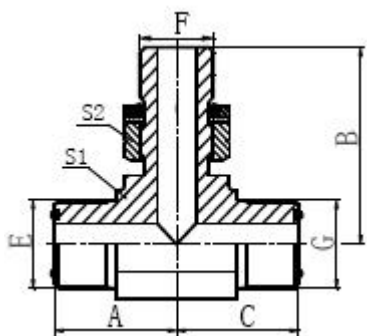

AFGF-OG

ORFS 外螺纹/英管外螺纹 O 形圈/ORFS 外螺纹

ORFS MALE/BSP MALE O-RING/ORFS MALE

代号 P/N	螺纹 Thread			尺寸 DIMENSIONS					
	E	F	G	A	B	C	S1	S2	
AFGF-04OG	9/16"X18	G1/4"X19	9/16"X18	23	31.3	23	14	19	
AFGF-06OG	11/16"X16	G3/8"X19	11/16"X16	27.5	36.8	27.5	19	22	
AFGF-08OG	13/16"X16	G1/2"X14	13/16"X16	31	43.2	31	22	27	
AFGF-10-12-10OG	1"X14	G3/4"X14	1"X14	36.5	49.3	36.5	27	32	
AFGF-12OG	1.3/16"X12	G3/4"X14	1.3/16"X12	42	53	42	33	32	
AFGF-16OG	1.7/16"X12	G1"X11	1.7/16"X12	48	58	48	41	41	

NOTES

The drawings in this catalogue are for reference only, and their dimensions and proportions may be a little different from those of the real products.

Products included in this catalogue don't refer to all, so if customers are interested in other products, please don't hesitate to contact our company for further information.

Our company has made much effort to record the correct data in this publication. However, in order to promote our products, we may make some changes of their size or description, which haven't been shown yet. We reserve the rights for explanation, but sorry for no further notice to customer the change of products' design, description or even stop of some products' manufacture in future.